

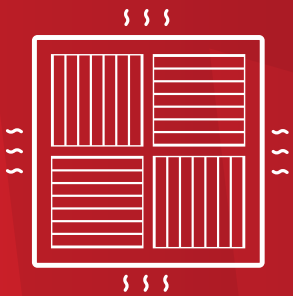

COMPONENTS CATALOGUE



aad.net.au

V2

DIRECT TO TRADE



Note: The Components Catalogue V2 contains information on the whole range of components that AAD sell.

Copyright: These materials are copyright. No part of them may be reproduced, adapted, translated, or transmitted without the prior written permission of the copywrite owner, Australian Airconditioning Distributor. Except under any permitted circumstances set out in the Copyright Act 1968.

AAD - Australian Airconditioning Distributors
ABN - 43 139 947 363

ABOUT AAD



WHO WE ARE

Australian Airconditioning Distributors Pty Ltd – Is completely focused on supporting the needs for trade's people servicing the HVAC (Heating, Ventilation and Airconditioning) industry, covering both the commercial and residential sectors.

Carrying a complete range of equipment covering refrigerated airconditioning units, evaporative coolers & gas ducted heaters, duct and fittings and spare parts, combined with technical support with over 100 years of airconditioning experience in design, application and installation.

“Grab all the gear you need to get your project completed from one of our conveniently located warehouses.”

GREAT BRANDS AT GREAT PRICES

By carrying a world class range of products and components AAD is determined to become the one stop shop for all of your HVAC needs, letting you to spend more time on the job and less time sourcing product.

AAD offers:

1. An Extended Range of major branded world class Air Conditioning products and components.
2. A Complete Range of accessories and components from duct fittings to refrigeration and plumbing supplies.
3. Convenient ordering – quick and easy order processing in person, via the phone, fax or email.
4. Technical Advice – our experienced team of engineers will provide technical support and solutions to back you up in the field.
5. Convenient trading hours – saving your time to spend more time at site.
6. Complete delivery service – ready to meet you on site as early as 7am.

AAD - Australian Airconditioning Distributors

ABN: 43 139 947 363

COMPANY SERVICES



ORDERING

As we carry significant stock, we are able to turn around your job requirements to suit your busy day. Simply call, text, fax or email your order on your way in and we can have ready for you to collect and go.

Same day orders, if you can have your order in by 11am, we can have it ready for later that afternoon.

For next day early morning collect or delivery, orders must be placed before 2pm the day prior.

PAYMENTS

Other than established trading accounts, all payments are C.O.D Payment can be made via:

CREDIT CARD

Most credit cards are accepted*

For credit card payments

Please fill out credit card authorisation form, to enable us to process your order quickly. Credit card payments over the phone require card name and CCV number.

*Fees apply to credit card payments.

EFT

For all EFT payments

Account: Australian Airconditioning Distributors

Bank BSB: 013 437

Account No: 5266 16395

Copy of EFT receipt must be faxed / emailed before goods can be released.

DELIVERY SERVICES

For deliveries within the Melbourne metro area our delivery service carry a flat rate of \$30.00. Deliveries can be made first thing in the morning to after 5:00pm at night.

Please allow up to a 3 hour turn around time between pick up and delivery, unless pre-ordered the previous business day.

- Early morning next day delivery requests should be made by 2:00pm the day prior.
- The above stated delivery times are based on the service availability of couriers and AAD drivers.
- For any delivery requirements outside of the Melbourne metro area, please call us to request a quote and time frame.
- Please ensure there are people on site to meet the driver and are capable to unload the goods. Detention time fees will be charged for any excessive waiting.



LOCATIONS

VIC CLAYTON

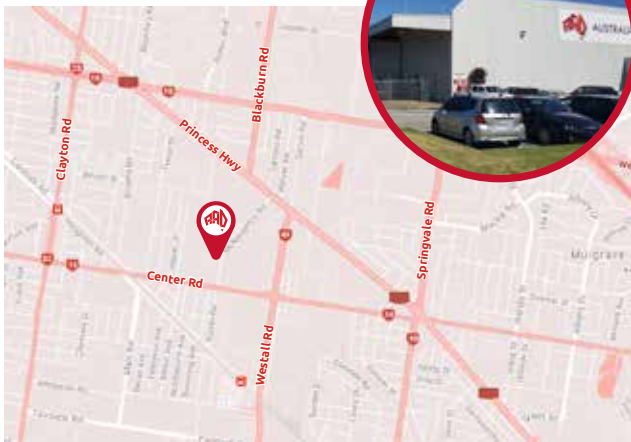

Head Office & Distribution Centre

Servicing the South Eastern Suburbs

57-63 McNaughton Road, Clayton, VIC 3168
P.O. Box 392 Springvale, VIC 3171

Operating Hours

Mon-Fri: 7:00am - 5:00pm
Saturday: 7:30am - 11:30am

T: 1300 223 223 (1) E: aadclayton@aad.net.au

VIC EPPING

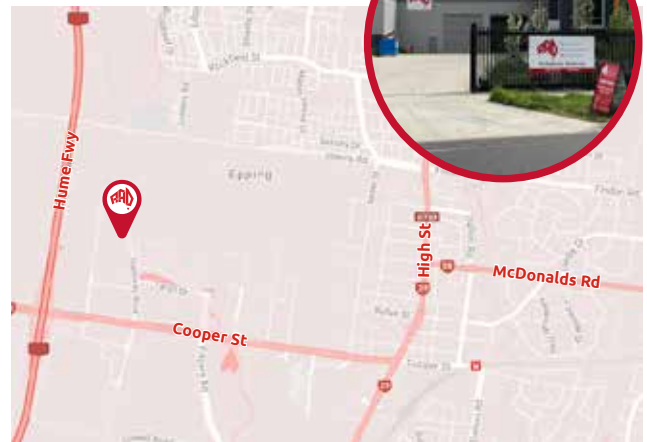

Servicing the Northern Suburbs

65 Gateway Boulevard, Epping, VIC 3076

Operating Hours

Mon-Fri: 7:00am - 5:00pm
Saturday: 7:30am - 11:30am

T: (03) 9099 8860 E. epping@aad.net.au

VIC HALLAM

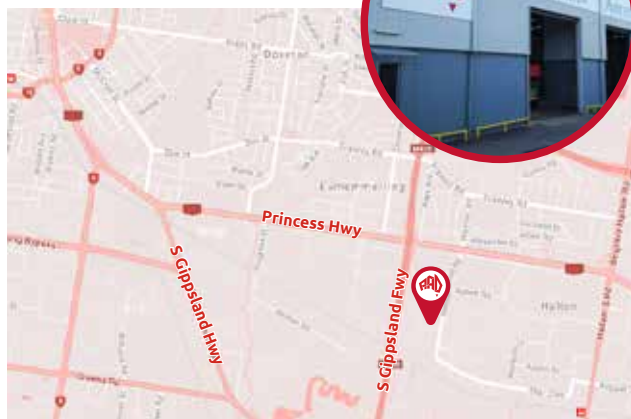

Servicing the Eastern Suburbs

59 Wedgewood Road, Hallam, VIC 3803

Operating Hours

Mon-Fri: 7:00am - 5:00pm
Saturday: 7:30am - 11:30am

T: (03) 8786 3990 E. hallam@aad.net.au

VIC BAYSWATER



Servicing the Eastern Suburbs

27 Corporate Boulevard, Bayswater, VIC 3153

Operating Hours

Mon-Fri: 7:00am - 5:00pm
Saturday: 7:30am - 11:30am

T: (03) 9720 1977 E. bayswater@aad.net.au

**VIC LAVERTON****Servicing the Western Suburbs**

22 Westside Drive, Laverton North, VIC 3026

Operating Hours

Mon-Fri: 7:00am - 5:00pm

Saturday: 7:30am - 11:30am

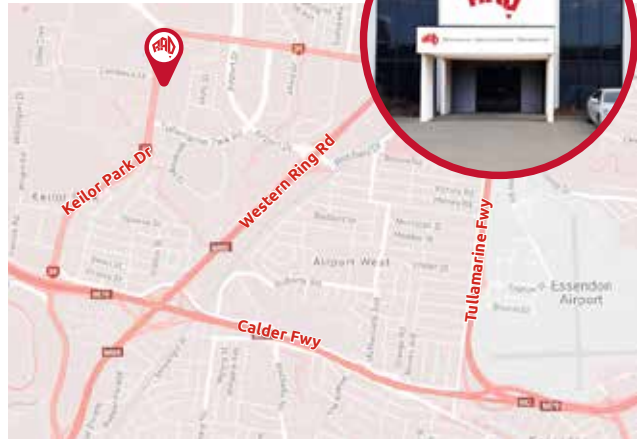
T: (03) 9314 9679 E. laverton@aad.net.au**VIC TULLAMARINE****Servicing the Western Suburbs**

112 Lambeck Drive, Tullamarine, VIC 3043

Operating Hours

Mon-Fri: 7:00am - 5:00pm

Saturday: 7:30am - 11:30am

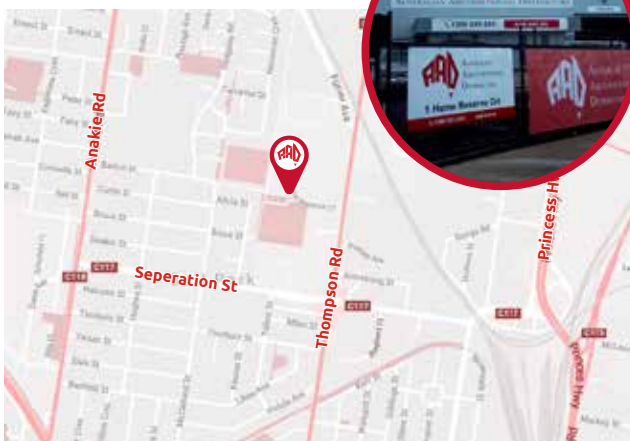
T: (03) 9338 8489 E. tullamarine@aad.net.au**VIC GEELONG****Servicing the Greater City of Geelong**

1 Hume Reserve, Bell Park, VIC 3215

Operating Hours

Mon-Fri: 7:00am - 5:00pm

Saturday: 7:30am - 11:30am

T: (03) 8571 7878 E. geelong@aad.net.au**NSW ARNDELL PARK****NSW Head Office & Distribution Centre
Servicing Sydney**

26 Penny Place, Arndell Park, NSW 2148

Operating Hours

Mon-Fri: 6:00am - 5:00pm

Saturday: 7:00am - 11:00am

T: (02) 9831 8286 E. arndell@aad.net.au

INDEX

GENERAL INFORMATION

About AAD	2
Company Services	3
Locations	4-5
Account Application	126
Terms and Conditions of Sale	131

VORTEX FLEXIBLE DUCTS

Flexible Duct	9
Nude Core	10

GRILLES & DIFFUSERS

MDO's - NEW	12-13
Bar Grilles	14
Linear Slots	15
Metal Grilles	16
Commercial Grilles	17
Metal Return Air Grilles - NEW	18
Metal Eggcrates	19
Plastic Return Grilles	20
Plastic Diffusers	21
Metal Floor Registers	22
Plastic Floor Registers	23
Plastic Grilles	24

FITTINGS

BTO's	26
DBTO's	27
Combos	28
Reducers & Boots	29
Starters & Joiners	30
Dampers	31
Cushion Head Boxes	32
Return Air Boxes	33
Metal Neck Adaptors	33

TRANSITIONS

Daikin	35
Fujitsu	35
Mitsubishi Electric	36
Samsung	36
Toshiba	37
Panasonic	37
Lennox	37

ZONE MANAGEMENT

MACzone3 Features & Benefits	39-42
MACzone3 Components	43-45
Air Network Terminals	46-47
Red Zone Dampers	48
Exactair Regulators	49-61
Thermostats	62-63
Smart Temp Zoning	64

EVAPORATIVE COOLING

Weatherguard Flashing & Droppers	66
Metal Flashing & Droppers	67
Plastic Plenums & Plates	68
Pumps	68

VENTILATION

Mix Flow Fans	70-72
Grilles	73
Low Profile Duct	74
Roof Cowls & Kits	75

ELECTRICAL

Cables & Ties	77
Isolators - NEW	78
RCBO's - NEW	78
Junction Boxes - NEW	78
Conduit - NEW	79
Accessories	79



COPPER

Pair Coil	81
Soft Drawn	81
Hard Drawn	81
Aradon Fittings - NEW	82-83
Zoom Lock - NEW	84-87

PIPE INSULATION

Pipe Insulation	89
-----------------	----

CAPPING

Metal Capping	91
Plastic Capping	92-93

UNIT MOUNTING

Brackets & Feet	95
Suspension	96
Chipboard	97
Slabs - NEW	97
Condenser Cages	97
Installation Hardware	98-101
Hoop Iron	99
Sealants & Sprays	102

DRAINAGE

Condensate Pumps	104-105
Flexible Drain Hose	106
Drip Trays	106
Dektites	107
Elephant Roof Seal Kit - NEW	108

PVC

Pipe & Joiners	110
Sockets	111
Saddle Clips	112
PVC Glue	112

TAPES

All Tapes	114
-----------	-----

FLUE

Cowls & Bends	116
Chinaman Hats	117

TOOLS

Vac Pumps - NEW	119
Manifolds - NEW	119
Tube Benders - NEW	120
Ratchet Wrench - NEW	120
Core Remover - NEW	120
Flaring Block - NEW	121
Tube Cutters - NEW	121
Bending Springs	121
Mapp Gas	122
Reamers	122
Oils	123
Additives	123

CELDEK PADS

All brands	125
------------	-----

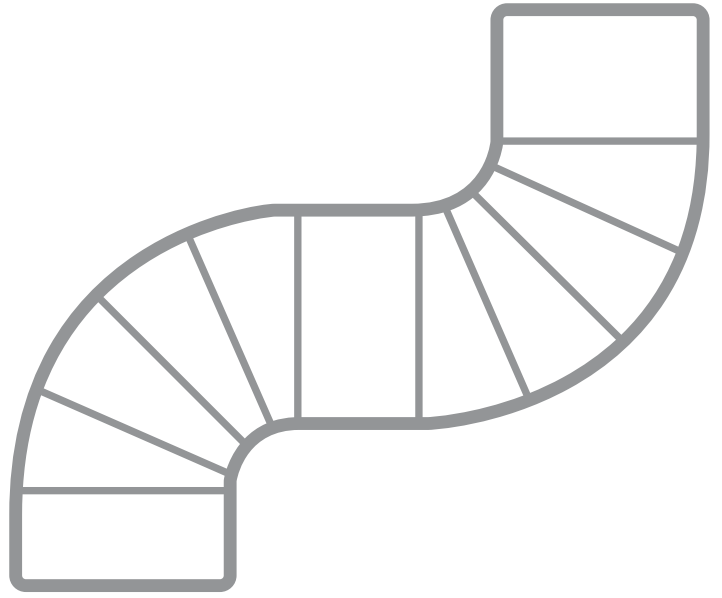



Vortex Duct Complies with Australian Standard AS 4254.1

R1.0 Is now the minimum standard R-Value for domestic roof or under floor installations

- Gas Ducted
- Add on cooling or reverse cycle
- Evaporative Cooling

R1.5 Is required in many combined heating and cooling installations including those installed in alpine regions (Climate Zone 8)

- Absence of sarking directly beneath the roofing
- Underfloor space is not enclosed by brickwork or cladding

R0.6 can still be used within the insulated building envelope - within the floor trusses or posy-struts between floors in a multi-storey dwelling, or within internal service risers.

Ductwork insulation is defined by the "insulation blanket R-value"

For commercial, there are a number of varying R-value requirements – please refer ADMA website or your copy of the NCC. www.adma.net.au

- Metalised inner core wrapped in R1.0 polyester insulation covered in a metalised outer fire jacket.
- Operating Temperature -20°C to +80°C
- Operating Pressure -190pa + 1200pa
- Domestic and Commercial Systems - Heating or Cooling
- Complies with AS4254.1

VORTEX - R0.6

PART NO.	SIZE (mm)
VF150	150
VF200	200
VF250	250
VF300	300
VF350	350
VF400	400
VF450	450
VF500	500

VORTEX EXTRA - R1.0

PART NO.	SIZE (mm)
VE150	150
VE200	200
VE250	250
VE300	300
VE350	350
VE400	400
VE450	450
VE500	500

VORTEX PREMIUM - R1.5

PART NO.	SIZE (mm)
VP150	150
VP200	200
VP250	250
VP300	300
VP350	350
VP400	400
VP450	450
VP500	500

R2.0 and Accoustic flexible duct available upon request

NUDE CORE



3 ZERO - NUDE CORE - 6M



Vortex Duct Complies with Australian Standard

3-Zero Nude Core is made up of:

- 1 Layer metalised film (outer layer)
- Water based **Flame Retardant** adhesive
- 1 Layer of clear film (inner surface)

4-Zero Nude Core is made up of:

- 1 Layer metalised film (outer layer)
- Water based **Flame Retardant** adhesive
- 1 Layer of aluminium laminate to 1 layer of clear film (2 layers)
- Ideal for rangehoods

- Metalised Core - Un-Insulated - General Use: Exhaust - Ventilation Systems
- Metalised Black Inner
- Fire Rated
- Operating Temperature -20°C to +80°C
- Operating Pressure -190pa to +1200pa

PART NO.	SIZE (mm)
NC64	100
NC65	125
NC66	150
NC68	200
NC610	250
NC612	300
NC614	350

4 ZERO - NUDE CORE - 6M

PART NO.	SIZE (mm)
4ZNC5	125
4ZNC6	150
4ZNC8	200

FITTINGS

TRANSITIONS

ZONE MANAGEMENT

AIR DIFFUSERS AND GRILLES

EVAPORATIVE COOLING

VENTILATION

ELECTRICAL

COPPER

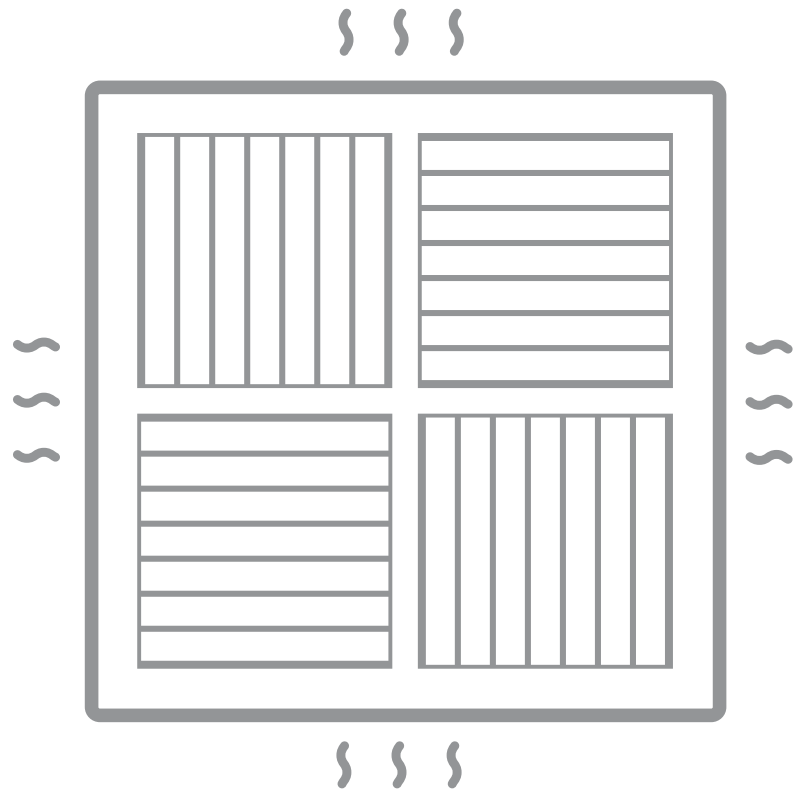

GRILLES & DIFFUSERS





Contemporary Style - Matte finish with high gloss louvres

Modern Appearance - Recessed louvres for a cleaner profile

Perfect Fit - Clip in modules ensure they stay in place especially when wall mounting is required

Ergonomic Design - Mounting clips makes installation an ease with no more sore fingers as they are easily installed and equally easy to remove

Better Fit - Unlike spring loaded snap systems our mounting clips ensure a snug fit to any surface

Built in Resistance - Louvres are designed to rotate with resistance to get that desired airflow



VORTEX DUCT
FITTINGS
TRANSITIONS
ZONE MANAGEMENT
AIR DIFFUSERS AND GRILLES
EVAPORATIVE COOLING
VENTILATION
ELECTRICAL
COPPER

MULTI DIRECTIONAL DIFFUSERS



PART NO.	MODULES	SIZE (mm)
SR15	2 Way	300 x 150
SR24	4 Way	240 x 240
SR30	4 Way	300 x 300
SR36	4 Way	360 x 360
SR40*	4 Way	400 x 400
SR54	6 Way	540 x 360

ADAPTORS



PART NO.	SUITS	SIZE (mm)
SRA1515	SR15	150
SRA1520	SR15	200
SRA1525	SR15	250
SRA2415	SR24	150
SRA2420	SR24	200
SRA2425	SR24	250
SRA3020	SR30	200
SRA3025	SR30	250
SRA3030	SR30	300
SRA3630	SR36	300
SRA3635	SR36	350
SRA3640	SR36	400
SRA4035	SR40	350
SRA4040	SR40	400
SRA5440	SR54	400
SRA5445	SR54	450
SRA5450	SR54	500

CUSHION HEAD - PLASTIC

- Fits SR24
- Cut pop to size - (150 or 200mm)

PART NO.	SUITS	SIZE (mm)
SRCH2486	SR24	150/200



BAR GRILLES

select range

BAR GRILLES

CUSHION HEAD BOXES

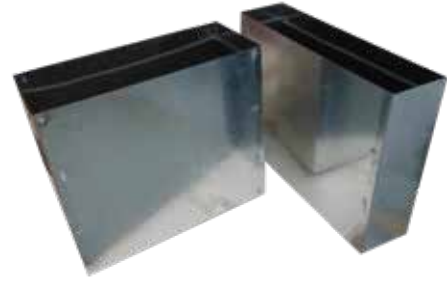

PART NO.	SIZE (mm)
100	
BG3010	297 x 97
BG4010	397 x 97
BG6010	597 x 97
BG9010	897 x 97
BG11510	1147 x 97
BG12010	1197 x 97
150	
BG3515	347 x 147
BG6015	597 x 147
BG9015	897 x 147
BG11515	1147 x 147
BG12015	1197 x 147
BULK HEAD RANGE	
BG6321	635 x 210
BG6514	655 x 145
BG7120	715 x 200
BG7125	715 x 250
BG8418	840 x 180
BG8514	855 x 145
BG10514	1055 x 145

PART NO.	SIZE (mm)
100	
CHB3010	300 x 100
CHB4010	400 x 100
CHB6010	600 x 100
CHB9010	900 x 100
CHB11510	1150 x 100
CHB12010	1200 x 100
150	
CHB3515	350 x 150
CHB6015	600 x 150
CHB9015	900 x 150
CHB11515	1150 x 150
CHB12015	1200 x 150
BULK HEAD RANGE	
CHB6321	640 x 215
CHB6514	660 x 150
CHB7120	720 x 205
CHB7125	720 x 255
CHB8418	845 x 185
CHB8514	860 x 150
CHB10514	1060 x 150

Compatible Bulkhead Units:

- **BG6321** - TOSH RAS-M10 / 13 / 16GDV-E
- **BG6514** - ME-SEZ , KD25
- **BG7120** - PANA CS-E12QD3RW
- **BG7125** - PANA CS-E18QD3RW
- **BG8418** - SAMSUNG MH052FUEA
- **BG8514** - ME SEZ - KD35/KD50, DAI FDXS25 / 35LVMA, SAMSUNG MH026/035FEEA
- **BG10514** - ME SEZ-KD60 / 71, DAIKIN FDXS50 / 60LVMA

LINEAR SLOTS

LINEAR SLOTS

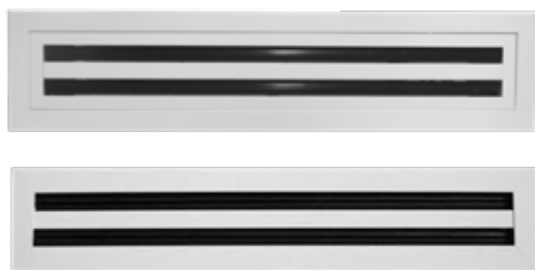

PART NO.	SIZE (mm)
REMOVABLE CORE	
LSD595	600 x 97
LSD2900	900 x 97
LSD21150	1150 x 97
LSD21200	1200 x 97
LSD21450	1450 x 97
LSD21750	1750 x 97
LSD22500	2500 x 97
FIXED CORE	
LSD690F	600 x 90
LSD890F	800 x 90
LSD1090F	1000 x 90
LSD2090F	2000 x 90

CUSHION HEAD BOXES

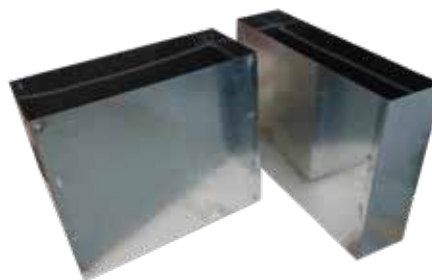

PART NO.	SIZE (mm)
CUSHION HEAD BOXES TO SUIT	
CHB6010	600 x 100
CHB9010	900 x 100
CHB11510	1150 x 100
CHB12010	1200 x 100
CHB21450	1450 x 100
CHB21750	1750 x 100
CHB25010	2500 x 100
CUSHION HEAD BOXES TO SUIT	
CHB690	605 x 95
CHB890	805 x 95
CHB1090	1005 x 95
CHB2090	2005 x 95

METAL GRILLES

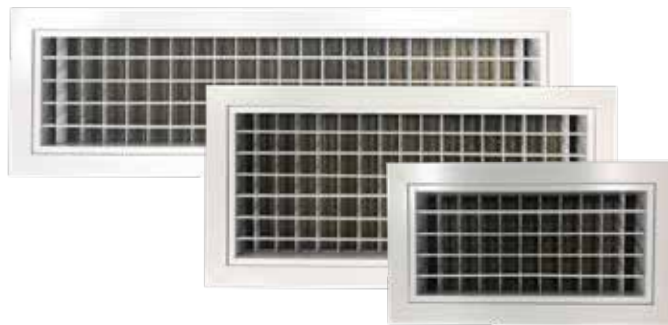

DOUBLE DEFLECTION - REMOVABLE CORE

PART NO.	SIZE (mm)
DOUBLE DEFLECTION GRILLES	
DD3010	297 x 97
DD3015	297 x 147
DD3515	347 x 147
DD4015	397 x 147
DD4020	397 x 197
DD4515	447 x 147
DD4520	447 x 197
DD5020	497 x 197
DD6015	597 x 147

PART NO.	SIZE (mm)
CUSHION HEAD BOXES TO SUIT	
CHB3010	300 x 100
CHB3015	300 x 150
CHB3515	350 x 150
CHB4015	400 x 150
CHB4020	400 x 200
CHB4515	450 x 150
CHB4520	450 x 200
CHB5020	500 x 200
CHB6015	600 x 150

DOOR RELIEF GRILLE - 2 PEICE



PART NO.	SIZE (mm)
DRG6015	600 x 150
DRG6020	600 x 200
DRG6025	600 x 250
DRG6030	600 x 300
DRG6040	600 x 400
DRG6060	600 x 600

WEATHERPROOF LOUVRE



PART NO.	SIZE (mm)
WP1515	145 x 145
WP2020	195 x 195
WP3030	295 x 295
WP4020	395 x 195
WP4040	395 x 395

COMMERCIAL GRILLES

LAY-IN 4 WAY ALUMINIUM DIFFUSERS

PART NO.	SIZE (mm)
4 WAY	
ALD445	445 x 445 - 300
ALD595	595 x 595 - 450
SWIRL	
SWDA595	595 x 595 - 450
ALUMINIUM PLASTER FRAME TO SUIT	
ALD445F	ALD445
ALD595F	ALD595 / SWDA595

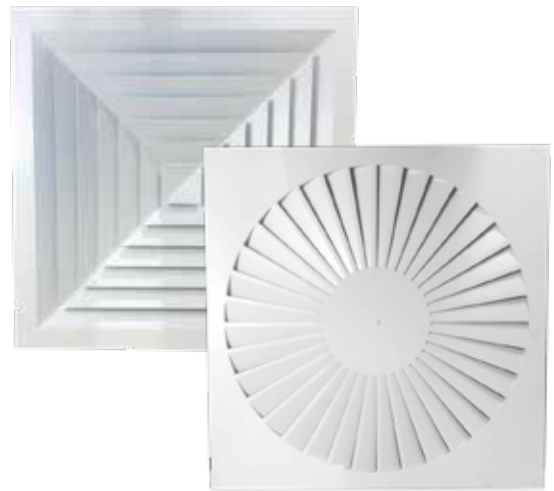

LAY-IN 4 WAY PLASTIC DIFFUSERS

PART NO.	SIZE (mm)
ST60MET4	595 x 595 - 450
ADAPTORS	
N4030	300
N4035	350
N4040	400



BEVEL EDGED PLASTIC DIFFUSERS

- Louvre faced

PART NO.	SIZE (mm)
ST303	280 x 280 - 3 WAY
ST304	280 x 280 - 4 WAY
ADAPTORS	
N3020	200
N3025	250
N3030	300



METAL RETURN AIR GRILLES

select range

FILTERED



PART NO.	SIZE (mm)
ECF3030	300 x 300
ECF4040	400 x 400
ECF5040	500 x 400
ECF5050	500 x 500
ECF6040	600 x 400
ECF7540	750 x 400
ECF7550	750 x 500
ECF8030	800 x 300
ECF8050	800 x 500
ECF9040	900 x 400
ECF9050	900 x 500
ECF10040	1000 x 400
ECF1050	1000 x 500
ECF1240	1200 x 400
ECF15040	1500 x 400
ECF595	1/2 T-Bar 550 x 550
ECF1195	Full T-Bar 1150 x 550
NSW Only - Heavier Filter (not stocked in VIC)	
ECF7545	750 x 450
ECF7555	750 x 550
ECF9045	900 x 450
ECF9055	900 x 550

HALF CHEVRON - FILTERED

NEW



HINGED FACE
For easy filter access

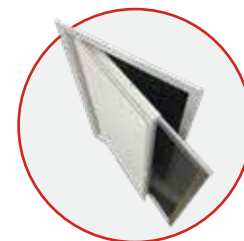

PART NO.	SIZE (mm)
SD6040	600 x 400
SD7540	750 x 400
SD9040	900 x 400
SD9050	900 x 500
SD10040	1000 x 400
SD12040	1200 x 400

FLAT PACKED

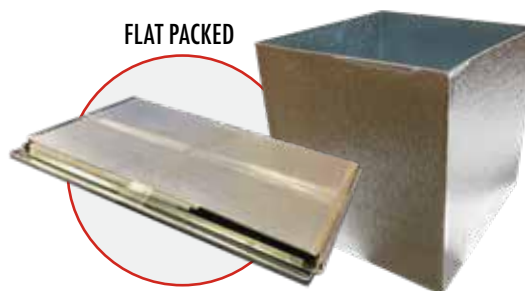

For a full list of flat pack return air boxes refer to page 33

EGGRATES - PLAIN

- Plain aluminium



PART NO.	SIZE (mm)
ECP1515	150 x 150
ECP2020	200 x 200
ECP3030	300 x 300
ECP4040	400 x 400
ECP6040	600 x 400

T-BARS

ECP295	1/4 T-Bar 550 x 250
ECP595	1/2 T-Bar 550 x 550
ECP1195	Full T-Bar 1150 x 550

NSW Only (not stocked in VIC)

ECP4545	450 x 450
---------	-----------

EGGRATES - PLAIN WITH ADAPTOR

- Plain aluminium



PART NO.	SIZE (mm)
ECA1515	150 x 150 - Neck: 150
ECA2015	200 x 200 - Neck: 150
ECA2020	200 x 200 - Neck: 200
ECA2520	250 x 250 - Neck: 200
ECA3025	300 x 300 - Neck: 250

PLASTIC RETURN AIR GRILLES

select range

PALTECH BASIC

- 510 x 380mm



PART NO.	DESCRIPTION
PRAG5138NF	Plain Grille
PRAG5138F	Filtered Grille
PRAB513812	Adaptor Box - 300
PRAB513814	Adaptor Box - 350
BL5138	Backing Flange
MF5138	Mounting Frame

PALTECH BASIC

- 760 x 400mm



PART NO.	DESCRIPTION
PRAG7640NF	Plain Grille
PRAG7640F	Filtered Grille
PRAB764014	Adaptor Box - 350
PRAB764016	Adaptor Box - 400
BL7640	Backing Flange
MF7640	Mounting Frame

PURTECH BASIC



PART NO.	SIZE (mm)
PUR7555B	750 x 550
PUR9040B	900 x 400
PUR1260B	1200 x 600

PURTECH BASIC WITH FILTER



PART NO.	SUITS	SIZE (mm)
PURTECH FILTERS		
FIL7555CD	Core Filter	750 x 550
FIL9040CD	Core Filter	400 x 900
FIL1260CD	Core Filter	600 x 1200

PLASTIC DIFFUSERS

select range

DOWN JETS



PART NO.	SIZE (mm)
DJ150	150
DJ200	200
DJ250	250

CONE DIFFUSERS



PART NO.	SIZE (mm)
CD150	150
CD200	200
CD250	250
CD300	300

ROUND EGGCRATES



PART NO.	SIZE (mm)
ECR150	150
ECR200	200
ECR250	250

SQUARE EGGCRATES



PART NO.	SIZE (mm)
ECA150	150
ECA200	200

PIPE INSULATION

CAPPING

UNIT MOUNTING

DRAINAGE

PVC

TAPES AND STRAPS

FLUE

TOOLS

CELDEK PADS

METAL FLOOR REGISTERS

METAL

PART NO.	COLOUR	SIZE (mm)
FGM3010	Beige	300 x 100
FGM3515	Beige	350 x 150
FGM3010CHM	Chrome	300 x 100
FGM3515CHM	Chrome	350 x 150
FGM3010MB	Matt Black	300 x 100
FGM3515MB	Matt Black	350 x 150



KICK RAIL

PART NO.	COLOUR	SIZE (mm)
FGM3050	White	300 x 50



HERITAGE

PART NO.	COLOUR	SIZE (mm)
FGH3010AB	Antique Brass	300 x 100
FGH3010BS	Polished Brass	300 x 100
FGH3010CHM	Chrome	300 x 100
FGH3010MB	Matt Black	300 x 100



HEAVY DUTY

PART NO.	COLOUR	SIZE (mm)
FGHD5030	Floor Grille Beige	500 x 300
RA3050	Return Air Box	500 x 300

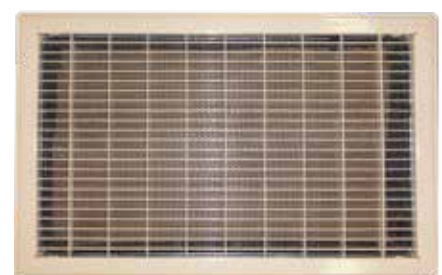

VORTEX DUCT

FITTINGS

TRANSITIONS

ZONE MANAGEMENT

AIR DIFFUSERS AND GRILLES

EVAPORATIVE COOLING

VENTILATION

ELECTRICAL

COPPER

PLASTIC FLOOR REGISTERS

300 x 100		350 x 150		COLOUR
PART NO.	PART NO.	PART NO.	PART NO.	
FG3010BE	FG3515BE	FG3010BN	FG3515BN	Beige
FG3010CH	FG3515CH	FG3010CM	FG3515CM	Brown
FG3010DB	FG3515DB	FG3010GY	FG3515GY	Chocolate
FG3010PE	FG3515PE	FG3010SE	FG3515SE	Cream
FG3010SL	FG3515SL	FG3010WE	FG3515WE	Dark Beige
				Grey
				Pine
				Slate
				Steel
				White

- 10 Colours
- 2 Sizes
- Twin Dampers



PLASTIC GRILLES

MD WALL REGISTERS & ADAPTORS



PART NO.	SIZE (mm)
MDRWHITE	300 x 100
MDRLWHITE	350 x 150
ADAPTORS	
MDR3015	300 x 100 - Neck: 150
MDR3020	300 x 100 - Neck: 200
MDR3520	350 x 150 - Neck: 200
MDR3525	350 x 150 - Neck: 250

LINEAR ELITES & ADAPTORS

- ABS Plastic
- 1195 x 138mm



PART NO.	SIZE (mm)
LIN	Grille Only
LINC	Linear Complete With Boot
ADAPTORS	
N2020	200
N2025	250
N2030	300

AIRLINE LINEAR & ADAPTORS

- **ALG** includes both the grille and adaptor boot



PART NO.	SIZE (mm)
ALG	610 x 260
ADAPTORS	
N2020	200
N2025	250
N2030	300

BABY LINEARS & ADAPTORS

- ABS Plastic



PART NO.	SIZE (mm)
BLING	595 x 118
ADAPTORS	
BLIN20	200
BLIN25	250
BLING CLIP	Bag of 6

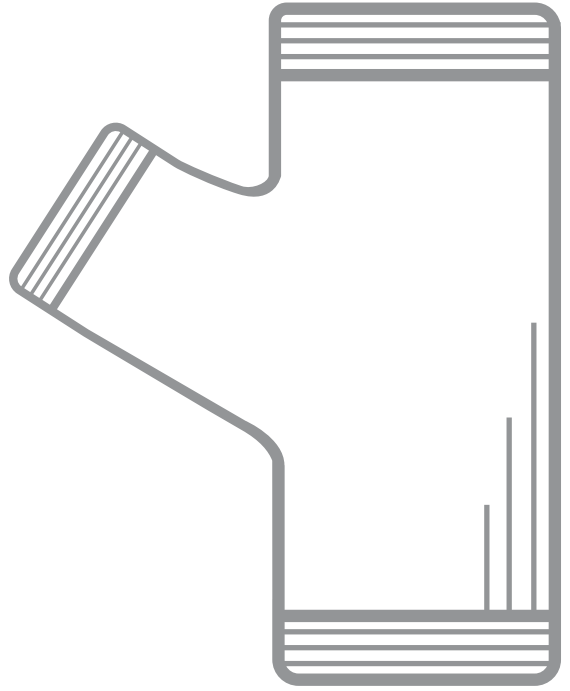

FITTINGS



BTO - BRANCH TAKE OFFS

INSULATED BTO

- R0.4 Compliant
- Meets AS/NZS 4859.1 - 2002



PART NO.	SIZE (mm)	SIZE (inch)
B666 (Plain)	150 - 150 - 150	6 - 6 - 6
B666I	150 - 150 - 150	6 - 6 - 6
B866I	200 - 150 - 150	8 - 6 - 6
B886I	200 - 200 - 150	8 - 8 - 6
B1066I	250 - 150 - 150	10 - 6 - 6
B1086I	250 - 200 - 150	10 - 8 - 6
B1088I	250 - 200 - 200	10 - 8 - 8
B10106I	250 - 250 - 150	10 - 10 - 6
B10108I	250 - 250 - 200	10 - 10 - 8
B1288I	300 - 200 - 200	12 - 8 - 8
B12106I	300 - 250 - 150	12 - 10 - 6
B12108I	300 - 250 - 200	12 - 10 - 8
B121010I	300 - 250 - 250	12 - 10 - 10
B12126I	300 - 300 - 150	12 - 12 - 6
B12128I	300 - 300 - 200	12 - 12 - 8
B121210I	300 - 300 - 250	12 - 12 - 10
B141010I	350 - 250 - 250	14 - 10 - 10
B14128I	350 - 300 - 200	14 - 12 - 8
B141210I	350 - 300 - 250	14 - 12 - 10
B141212I	350 - 300 - 300	14 - 12 - 12
B141410I	350 - 350 - 250	14 - 14 - 10
B141412I	350 - 350 - 300	14 - 14 - 12
B161410I	400 - 350 - 250	16 - 14 - 10
B161412I	400 - 350 - 300	16 - 14 - 12

DBTO - DOUBLE BRANCH TAKE OFFS

INSULATED DBTO

- R0.4 Compliant
- Meets AS/NZS 4859.1 - 2002



PART NO.	SIZE (mm)	SIZE (inch)
D8666I	200 - 150 - 150 - 150	8 - 6 - 6 - 6
D10666I	250 - 150 - 150 - 150	10 - 6 - 6 - 6
D10866I	250 - 200 - 150 - 150	10 - 8 - 6 - 6
D10888I	250 - 200 - 200 - 200	10 - 8 - 8 - 8
D101066I	250 - 250 - 150 - 150	10 - 10 - 6 - 6
D101088I	250 - 250 - 200 - 200	10 - 10 - 8 - 8
D12888I	300 - 200 - 200 - 200	12 - 8 - 8 - 8
D121066I	300 - 250 - 150 - 150	12 - 10 - 6 - 6
D121088I	300 - 250 - 200 - 200	12 - 10 - 8 - 8
D12101010I	300 - 250 - 250 - 250	12 - 10 - 10 - 10
D121288I	300 - 300 - 200 - 200	12 - 12 - 8 - 8
D14101010I	350 - 250 - 250 - 250	14 - 10 - 10 - 10
D141288I	350 - 300 - 200 - 200	14 - 12 - 8 - 8
D14121010I	350 - 300 - 250 - 250	14 - 12 - 10 - 10
D14121212I	350 - 300 - 300 - 300	14 - 12 - 12 - 12
D14141010I	350 - 350 - 250 - 250	14 - 14 - 10 - 10
D16141010I	400 - 350 - 250 - 250	16 - 14 - 10 - 10
D16141212I	400 - 350 - 300 - 300	16 - 14 - 12 - 12

COMBOS

COMBO "Y" - INSULATED

- BCA Compliant

PART NO.	INLET A	OUTLET B	OUTLET C
Y1I	200	150	150
Y2I	250	150 - 200	150 - 200
Y3I	250 - 300	200 - 250	200 - 250
Y4I	300 - 350	250 - 300	250 - 300
Y5I	350 - 400	300 - 350	300 - 350
Y6I	400 - 450	300 - 350 - 400	300 - 350 - 400
Y7I	450 - 500	350 - 400 - 450	400 - 450



MULTI COMBO BTO - INSULATED

- R0.4 Compliant
- Meets AS/NZS 4859.1 - 2002

PART NO.	INLET A	OUTLET C	ARM B
MCB181610I	400 - 450	300 - 350 - 400	200 - 250
MCB181614I	400 - 450	300 - 350 - 400	300 - 350



MULTI COMBO DBTO - INSULATED

- R0.4 Compliant
- Meets AS/NZS 4859.1 - 2002



PART NO.	INLET A	OUTLET C	ARM B	ARM D
MCD18161010I	400 - 450	300 - 350 - 400	200 - 250	200 - 250
MCD18161410I	400 - 450	300 - 350 - 400	200 - 250	300 - 350
MCD18161414I	400 - 450	300 - 350 - 400	300 - 250	300 - 350

REDUCERS & BOOTS

REDUCERS - PLAIN

PART NO.	SIZE (mm)	SIZE (inch)
R2015	200 - 150	8 - 6
R2520	250 - 200	10 - 8
R3025	300 - 250	12 - 10
R3530	350 - 300	14 - 12
R4035	400 - 350	16 - 14
R4540	450 - 400	18 - 16
R5045	500 - 450	20 - 18



ANGLED FLOOR BOOTS

PART NO.	SIZE (mm)	OUTLET (mm)
AB301015	300 x 100	150
AB301020	300 x 100	200
AB351520	350 x 150	200
AB351525	350 x 150	250



PIPE INSULATION

CAPPING

UNIT MOUNTING

DRAINAGE

PVC

TAPES AND STRAPS

FLUE

TOOLS

CELDEK PADS

STARTERS & JOINERS

STARTER COLLARS

PART NO.	Size (mm)
SC150	150
SC200	200
SC250	250
SC300	300
SC350	350
SC400	400
SC450	450
SC500	500



JOINERS

PART NO.	Size (mm)
JM150	150
JM200	200
JM250	250
JM300	300
JM350	350
JM400	400
JM450	450
JM500	500



STARTER COLLARS WITH INLINE DAMPER

PART NO.	Size (mm)
SCMD150	150
SCMD200	200
SCMD250	250
SCMD300	300
SCMD350	350
SCMD400	400

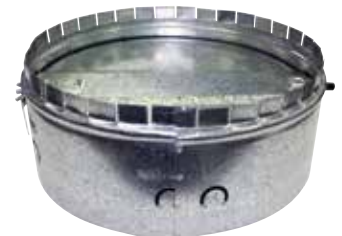

DAMPERS

MANUAL INLINE DAMPERS

PART NO.	Size (mm)
MAD08	200
MAD10	250
MAD12	300
MAD14	350



NON RETURN DAMPERS - SPRING LOADED

PART NO.	Size (mm)
NRD150	150
NRD200	200
NRD250	250



BELL MOUTH SPIGOTS WITH DAMPER

PART NO.	Size (mm)
BMS150	150
BMS200	200
BMS250	250
BMS300	300



RETURN AIR TOP HATS

PART NO.	SIZE (mm)
RAT300	300
RAT350	350
RAT400	400



CUSHION HEAD BOXES

CUSHION HEAD BOXES

- 5mm Internal Insulation



PART NO.	SIZE (mm)	SUITS
100		
CHB3010	300 x 100	BG3010 - DD3010
CHB4010	400 x 100	BG4010
CHB4020	400 x 200	BG4020
CHB4520	450 x 200	BG4520
CHB5020	500 x 200	BG5020
CHB6010	600 x 100	BG6010
CHB9010	900 x 100	BG9010
CHB11510	1150 x 100	BG11510
CHB12010	2000 x 100	BG12010
150		
CHB3015	300 x 150	DD3015
CHB3515	350 x 150	BG3515 - DD3515
CHB4015	400 x 150	DD4015
CHB4515	450 x 150	DD4515
CHB6015	600 x 150	BG6015 - DD6015
CHB9015	900 x 150	BG9015
CHB11515	1150 x 150	BG11515
CHB12015	1200 x 150	BG12015
200		
CHB4020	400 x 200	DD4020
CHB4520	450 x 200	DD4520
CHB5020	500 x 200	DD5020

CUSHION HEAD BOXES

- 5mm Internal Insulation



PART NO.	SIZE (mm)	SUITS
BULKHEAD RANGE		
CHB6321	640 x 215	BG6321
CHB6514	660 x 150	BG6514
CHB7120	720 x 205	BG7120
CHB7125	720 x 255	BG7125
CHB8418	845 x 185	BG8418
CHB8514	860 x 150	BG8514
CHB10514	1060 x 150	BG10514
LSD RANGE		
CHB690	605 x 95	LSD690F
CHB890	805 x 95	LSD890F
CHB1090	1005 x 95	LSD1090F
CHB2090	2005 x 95	LSD2090F
CHB21450	1450 x 100	LSD21450
CHB21750	1750 x 100	LSD21750
CHB25010	2505 x 103	LSD22500

SWIRL DIFFUSER PLENUM BOX

- T-Bar middle support bar
- Damper blade
- Coming soon



PART NO.	SIZE (mm)	POP SIZE (mm)
PBS200	595 x 595	200
PBS250	595 x 595	250
-	-	-

RETURN AIR BOXES & METAL NECK ADAPTORS

CUSHION HEAD BOXES - METAL T BAR

- Internally Insulated
- 450 x 450 Box Size
- Damper Blade



PART NO.	POP SIZE (mm)	SUITS
300x300		
CHB3030-20	200	ALD445
CHB3030-25	250	ALD445
450x450		
CHB4545-20	200	ALD595
CHB4545-25	250	ALD595
CHB4545-30	300	ALD595
CHB4545-35	350	ALD595
ADAPTORS		
CHBADPT43	300 - 445	
CHBADPT54	445 - 540	

RETURN AIR BOXES

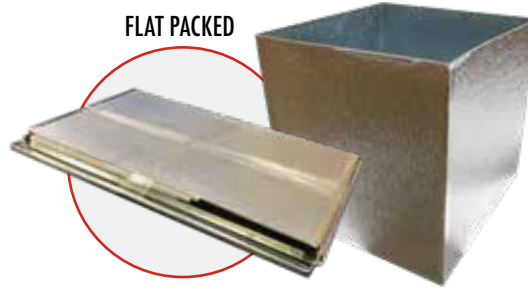

PART NO.	SIZE (mm)	SUITS
RA3050	300 x 500	FGHD3050
RA4040	400 x 400	ECP/ECF4040
RA5040	500 x 400	ECF5040
RA595	550 x 550	ECP/ECF595
RA6040	600 x 400	ECP/ECF/SD6040
RA7540	750 x 400	ECF/SD7540
RA7550	750 x 500	ECF7550
RA8030	800 x 300	ECF8030
RA8050	800 x 500	ECF8050
RA9040	900 x 400	ECF/SD9040
RA9050	900 x 500	ECF/SD9050
RA1040	1000 x 400	ECF/SD10040
RA1050	1000 x 500	ECF1050
RA1195	1150 x 550	ECP/ECF1195
RA1240	1200 x 400	ECF/SD1240
RA15040	1500 x 400	ECF15040

METAL NECK ADAPTORS



PART NO.	POP SIZE (mm)
300x300	
MA30D15	150
MA30D20	200
MA30D25	250



PART NO.	POP SIZE (mm)
450x450	
MA45D15	150
MA45D20	200
MA45D25	250
MA45D30	300
MA45D35	350

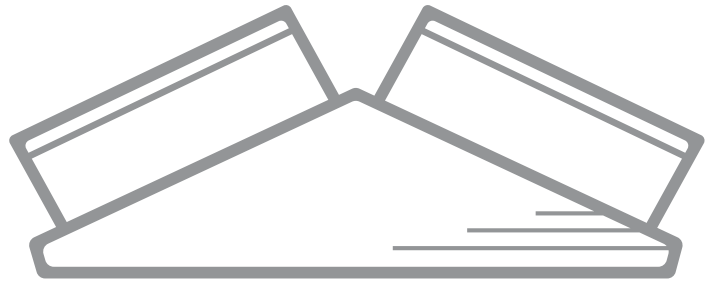

TRANSITIONS



TRANSITIONS

DAIKIN - NOSE CONE



PART NO.	CAPACITY	SIZE (mm)
NCDAI71LBVI	7kW	855x185-2x300
NCDAI100LBVI	10kW	855x245-2x350
NCDAI100-125	10-12kW	1150x245-2x350
NCDAI100-160LV1	10-16kW	1155x245-2x400
NCDAI140-160LAV	14-16kW	1155x320-2x400
NCDAI180-200	18-20kW	830x380-2x450
NCDAI250	25kW	940x380-2x450

FUJITSU - NOSE CONE



PART NO.	CAPACITY	SIZE (mm)
NCFUJIG30-36	9-10kW	855x295-2x300
NCFUJIG45	12kW	925x305-2x350
NCFUJIC54-60	14-15kW + 16kW 3P	855x295-2x400
NCFUJIG45-60LDT	16kW	1162x277-2x400
NCFUJIG54	14kW	925x305-2x400
NCFUJIC72	20kW 16kW 1P	1200x350-2x400
NCFUJIC90	25kW	1200x350-2x450

DAIKIN - SUPPLY AIR



PART NO.	CAPACITY	SIZE (mm)
SADAI71LBV	7kW	855x185-350
SADAI100LBV	10kW	855x245-400
SADAI100-125	10-12kW	1150x245-1x400
SADAI140-160	14-16kW	1155x385-1x450
SADAI140-160LAV	14-16kW	1155x320-1x450
SADAI140-160LV1	14-16kW	1155x245-1x450
SADAI180LCV1	18W	922x354-200
SADAI180-200	18-20kW	830x380-1x500
SADAI200-250LVC1	20-25kW	1120x354-1x20
SADAI250	25kW	940x380-1x500

FUJITSU - SUPPLY AIR



PART NO.	CAPACITY	SIZE (mm)
SAFUJIG30-36	9-10kW	855x295-1x350
SAFUJIG45	12kW	925x305-1x400
SAFUJIG36-54LHTD	10-13kW	1162x217-1x400
SAFUJIG54-60	14kW	925x305-1x450
SAFUJIC54-60	14-15kW	855x295-1x450
SAFUJIG45-60LDT	16kW	1162x277-1x450
SAFUJIC72	20kW + 16kW 1P	1200x350-1x450
SAFUJIC90	20kW	1200x350-1x500

DAIKIN - RETURN AIR



PART NO.	CAPACITY	SIZE (mm)
RADAI180LCV1	18kW	922x395x230
RADAI200-250LCV1	20-25kW	1120x395x230
RADAI200-250	20-25kW	1120x350x230
RADAI180	18kW	920x350x230

FUJITSU - RETURN AIR



PART NO.	CAPACITY	SIZE (mm)
RAFUJ-G24	7.1kW	1015 x 240
RAFUJ-G30-36	9-10kW	865 x 325
RAFUJ-G36 54LHTD	10-13kW	1295 x 255
RAFUJ-G45-60	12-15kW + 16kW 3P	1065 x 355
RAFUJ-G45-60LDT	16kW	1295 x 316
RAFUJ-C72	20kW	1250 x 370
RAFUJ-C90	25kW	1250 x 470

TRANSITIONS

MITSUBISHI - NOSE CONE



PART NO.	CAPACITY	SIZE (mm)
NCMIT71	7kW	1060x180-2x300
NCMITGAA100-125	10-12kW	925x255-2x350
NCMIT100-125	10 - 12kW	1360x180-2x350
NCMITGAA140	14kW	925x255-2x400
NCMITD140	14kW	1560x180-2x350
NCMIT170-250	17/20/25kW	1100x340-2x450

SAMSUNG - NOSE CONE



PART NO.	CAPACITY	SIZE (mm)
NCSAMAC71	7kW	820x225-2x250
NCSAMAC90	9kW	1170x225-2x300
NCSAMAC100	10kW	1270x275-2x350
NCSAMAC120-140	12 - 14kW	1270x275-2x400
NCSAMAC160	16kW	1284x360-2X400
NCSAMAC180-200	18 - 20kW	1284x360-2X450

MITSUBISHI - SUPPLY AIR



PART NO.	CAPACITY	SIZE (mm)
SAMIT71	7kW	1060x180-1x350
SAMITGAA100-125	10/12kW	925x255-1x400
SAMIT100-125	10/12kW	1360x180-1x400
SAMITGAA140	14kW	925x255-1x450
SAMITD140	14kW	1560x180-1x400
SAMIT170-250	17/20/25kW	1100x340-1x500

SAMSUNG - SUPPLY AIR



PART NO.	CAPACITY	SIZE (mm)
SASAMAC71	7kW	820x225-1x350
SASAMAC90	9kW	1170x225-1x350
SASAMAC100	10kW	1270x275-1x400
SASAMAC120-140	12 - 14kW	1270x275-1x450
SASAMAC160	16kW	1284x360-1x450
SASAMAC180-200	18 - 20kW	1284x360-1x500

MITSUBISHI - RETURN AIR



PART NO.	CAPACITY	SIZE (mm)
RAMIT71	7kW	1060x210*
RAMIT100-125	10/12kW	1360x210*
RAMITGAA100-140	10/12/14kW	1105 x 355
RAMITD140	14kW	1560x210*
RAMITD170-250	17/20/22kW	1100x420

* 20mm lip size

SAMSUNG - RETURN AIR



PART NO.	CAPACITY	SIZE (mm)
RASAMAC71	7kW	820 x 225
RASAMAC90	9kW	1170 x 225
RASAMAC100-140	10-14kW	1270 x 275
RASAMAC160-200	16-20kW	1284 x 360

TRANSITIONS

TOSHIBA - NOSE CONE



PART NO.	CAPACITY	SIZE (mm)
NCTOS110	10kW	275x760-2x350*
NCTOS140-160	12.5/13.5kW	275x760-2x400*

* 20mm lip

PANASONIC - NOSE CONE



PART NO.	CAPACITY	SIZE (mm)
NCPAN71-100	7/10kW	1025x270-2x300
NCPAN125	12kW	1025x340-2x350
NCPAN140	14kW	1025x340-2x400

TOSHIBA - SUPPLY AIR



PART NO.	CAPACITY	SIZE (mm)
SATOS110	10kW	275x760-1x400*
SATOS140-160	12.5/13.5kW	275x760-1x450*
SATOS224	16kW	345x1080-1x450**
SATOS280	20kW	345x1080-1x500**

* 20mm lip

** 25mm lip

PANASONIC - NOSE CONE



PART NO.	CAPACITY	SIZE (mm)
SAPAN60	6kW	1025x200-1x300
SAPAN71-100	7/10kW	1025x270-1x350
SAPAN125	12kW	1025x340-1x400
SAPAN140	14kW	1025x340-1x450
SAPAN200	20kW	970x325-1x500

TOSHIBA - RETURN AIR



PART NO.	CAPACITY	SIZE (mm)
RATOS110-160	10/12/14kW	275 x 845*
RATOS224-280	16/20kW	380 x 1080**

* 20mm lip

** 25mm lip

PANASONIC - RETURN AIR



PART NO.	CAPACITY	SIZE (mm)
RAPAN60	6kW	1025 x 200
RAPAN71-100	7/10kW	1025 x 270
RAPAN125-140	12/14kW	1025 x 340
RAPAN200	20kW	1075 x 305

LENNOX - TRANSITIONS

PART NO.	SIZE (mm)
LSATB-350	500 x 410 - 350
LSATB-400	500 x 410 - 400
LSATC-450	508 x 508 - 350
LSATC-350	508 x 508 - 350
LSATC-400	508 x 508 - 400
LSATD-400	590 x 515 - 400
LSATD-450	590 x 515 - 450



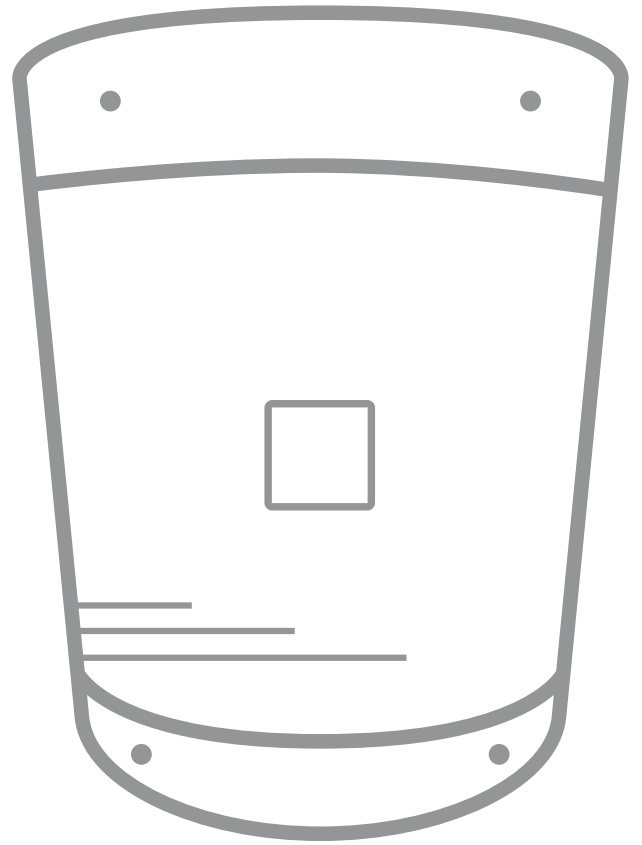

ZONE MANAGEMENT



Air conditioning for a smarter home.

For precision control of your ducted air conditioning.





MULTI-APPLICATION CONTROL



MAC ZONE 3 New generation climate control system works with all leading brands



MAC ZONE 3 Touch screen technology gives you total comfort control of your whole home. Adjust the air flow or temperature to any room.

Select up to 14 sensors/zones - every zone will maintain your required comfort levels. You can also direct airflow to only the rooms you choose for maximum efficiency and savings.

For even more control, ask about the isense controller, which maximises efficiency by detecting which rooms are unoccupied, to provide cooling and heating only when and where you need it.

OPTIONS

- AC UNIT CONTROL

- WiFi & 4G CONTROL

- ZONE TEMPERATURE CONTROL

- FAVOURITES AND SCHEDULES

- INTELLIGENT ROAMING SENSOR OPTION

- EXPAND UP TO 14 ZONES

- 5% AIRFLOW CONTROL ADJUSTMENTS

- UP TO 12 TOUCHSCREENS

- FILTER CLEAN ALERT WITH ADJUSTABLE FREQUENCY

- SLEEP TIMER

- FRESH AIR

- SMART LIGHTING

- SMART RETICULATION

- SMART POWER

- SMART SECURITY

SMART FEATURES

- Compatible with other home automation systems

- In duct supply air sensor for improved efficiency and temperature control

- Roaming sensor to ensure every zone is maintained at the exact temperature

- Temperature sensor in every touchscreen controller

- Zone on/off button on every sensor

- iSense occupancy sensor with backlit display and full in room temperature control

- Fan auto control to maximise comfort and minimise energy consumption

- Sensors can be calibrated for precision control

- IFTTT compatible

- Google Home compatible

MACzone3 is smarter too.



8 ZONE KIT

- 7" LCD SCREEN
- CENTRAL PROCESSING UNIT
- POWER SUPPLY
- CABLE
- INSTALLATION/USER MANUAL





 Precision engineered products and innovative technologies deliver unrivalled efficiency and control throughout your home. They save you money at the same time as keeping your family comfortable all year round.



LIGHTING

Downlights | Bulbs | 100 Whites
16 Million Colours



AIR CONDITIONING

Temperature Control | Zones
Sensors | Controllers



RETICULATION

Reticulation Controller
Weather Interface | Watering Cycles



SECURITY

Garage Door | Lighting

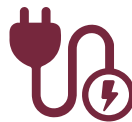

POWER

Smart Plugs | Appliances
Energy Monitoring



ENTERTAINMENT

Spotify | Soundcloud | Netflix
Apple | Google



*Conditions apply - 2 year warranty + 3 year extended warranty via registration

COMPONENTS

KITS

PART NO.	DESCRIPTION
CHC430KB	Nexus 8 Zone Kit - Black
CHC430KW	Nexus 8 Zone Kit - White



WIRELESS SENSORS

PART NO.	DESCRIPTION
CRFSB	Wireless Sensor - Black
CRFSW	Wireless Sensor - White



WIRED SENSORS

PART NO.	DESCRIPTION
CSB	Wired Sensor - Black
CSW	Wired Sensor - White
CWSMK	Wired Sensor Module



iSENSE SENSORS

PART NO.	DESCRIPTION
CZCOB	Zone Control iSense - Black
CZCOW	Zone Control iSense - White



IN-DUCT SENSOR

PART NO.	DESCRIPTION
CDTS	Supply Air In-Duct Sensor



COMPONENTS



SYSTEM EXPANSION

PART NO.	DESCRIPTION
C225	CPU
CCTSLB	LCD Screen - Black
CCTSLW	LCD Screen - White
CHCEXT	Zone Expansion
CISMK	System Multiplex 2-5 Unit
CNEMK	Screen Ext Kit 10+2
CT24AC	Transformer 24V



WIFI CONNECT

PART NO.	DESCRIPTION
CHCL5BK	WiFi Connect



VORTEX DUCT
FITTINGS
TRANSITIONS
ZONE MANAGEMENT
AIR DIFFUSERS AND GRILLES
EVAPORATIVE COOLING
VENTILATION
ELECTRICAL
COPPER

COMPONENTS



UNIT MODULES

- Ready to go

PART NO.	DESCRIPTION
CHC325D	Daikin
CHC325F	Fujitsu
CHC325M	Mitsubishi Electric
CHC325P	Panasonic
CHC325S	Samsung
CHC325T	Toshiba
CUCMK	Universal Gas Heater 24V



UNIT MODULES

- Not stocked, available via special request

PART NO.	DESCRIPTION
CHC325A	Actron
CHC325B	Braemar
CHC325H	Hitachi
CHC325HI	Haier
CHC325L	LG
CHC325MHI	MHI
CHC325R	Rinnai
CHC325TZ	Temper-Zone
CHC325Y	York



CABLES

PART NO.	DESCRIPTION
CFC1	Flat 1M
CFC12	Flat 12M
CFC25	Flat 25M
CDC25	White 25M
CGB2C35	WiFi CPU 35M



AIR NETWORK TERMINALS



Air Network Terminals - Are ideal for splitting air flows. They have much lower pressure drops than conventional plastic or sheet metal fittings resulting in better airflow throughout the system.

Air Network Terminals - Are constructed with Duct Board a pre-insulated aluminium / polyurethane sandwich panel comprising an expanded polyurethane rigid foam board, faced with 80microns of aluminium foil on both sides. Duct Board has been used in office buildings, apartments, industrial warehouses, hospitals, hotels, shopping centres and government buildings in Australia and across the globe.

Air Network Terminals - Are rated at R1.5 and all joints and spigots are sealed with foam gaskets and silicon ensuring no leakage, heat gain or condensation. This all adds up to greater system energy efficiency, lower running costs and improved comfort.

The advantages of Air Network Terminals over traditional sheet metal are:

- Excellent thermal insulation and vapour proofing
- Lower manufactured cost
- Lower installation cost
- Faster installation
- Light weight
- Up to 80% less air leakage
- 30% less embodied energy
- Better sound proofing and anti-vibration-damping effect
- Standard Height 400mm
- Spigot sizes range from 150 to 550mm diameter
- Clip-on zone dampers are available in sizes from 200 to 450mm diameter
- Flame Retardant – Class 0
- Working Temp. – 60oC to +80oC
- Max Pressure – 2000 Pa
- Green Rating – Non CFC and 0 ODP

BA2

- 1 IN - 2 OUT

BA2-1

Body: BP1
Inlet: 500-550
Outlet L: 200-ANY
Outlet R: 200-ANY

DIM: 730 x 730 x 730mm

BA2-3

Body: BP3
Inlet: 400-450
Outlet L: 200-ANY
Outlet R: 200-ANY

DIM: 575 x 575 x 575mm



BA3

- 1 IN - 3 OUT

BA3-9

Body: BP9
Inlet: 500-550
Outlet Top: 200-400
Outlet L: 200-400
Outlet R: 200-400

DIM: 735 x 495 x 495 x 495mm

BA3-12

Body: BP12
Inlet: 250-450
Outlet Top: 200-400
Outlet L: 200-400
Outlet R: 200-400

DIM: 575 x 495 x 495 x 495mm



BA4

- 1 IN - 4 OUT

BA2-5

Body: BP5
Inlet: 200-350
Outlet L: 200-ANY
Outlet R: 200-ANY

DIM: 495 x 495 x 495mm

BA4-1 (Double Out)

Body: BP1
Inlet: 350-500
Outlet L1 & L2: MIX 200-300
Outlet R1 & R2: MIX 200-300

DIM: 730 x 730 x 730mm



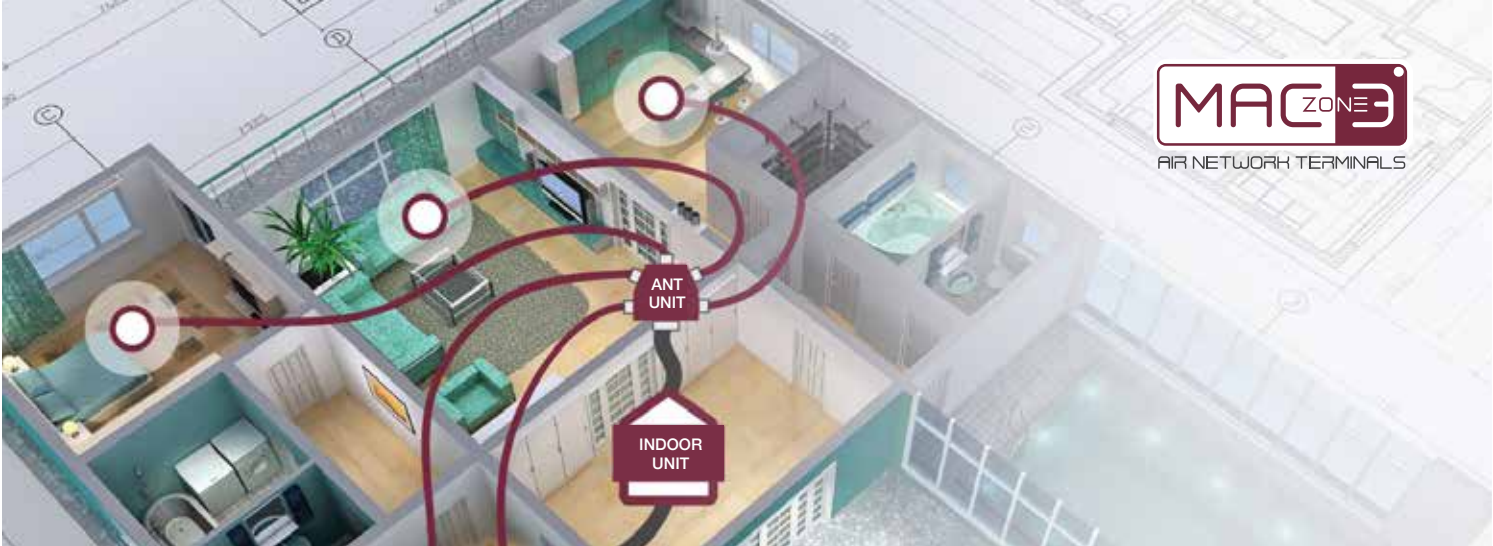

BA5

- 1 IN - 5 OUT

BA5-14

Body: BP14
Inlet: 500-550
Outlet Top: 200-300
Outlet L1 & L2: 200-300
Outlet R1 & R2: 200-300

BA5-18

Body: BP18
Inlet: 400-450
Outlet Top: 200-300
Outlet L1 & L2: 200-300
Outlet R1 & R2: 200-300

DIM: 700 x 350 x 350 x 350 x 350 x 350mm DIM: 550 x 350 x 350 x 350 x 350 x 350mm



MANUAL SPIGOTS



PART NO.	SIZE (mm)
BCIS20	200
BCIS25	250
BCIS30	300
BCIS35	350
BCIS40	400
BCIS45	450
BCIS50	500
BCIS55	550

MOTORISED SPIGOTS



PART NO.	SIZE (mm)
CCZDK20	200
CCZDK25	250
CCZDK30	300
CCZDK35	350
CCZDK40	400
CCZDK45	450

Go manual or motorised!

MOTORISED DAMPERS

- Available in 7 sizes
- 150 - 200 - 250 - 300 - 350 - 400 - 450

Features

- Galvanised Barrel
- 5mm Silver Insulation
- Folded Metal Blade
- 12mm Foam Seal
- Metal Shaft Motor
- C-Tick Certified
- Brass brushes for long life
- Drive open - Drive close
- Quiet and reliable operation



24 Volt

PART NO.	SIZE (mm)
MDM150L	150
MDM200L	200
MDM250L	250
MDM300L	300
MDM350L	350
MDM400L	400
MDM450L	450

240 Volt

PART NO.	SIZE (mm)
MDM150M	150
MDM200M	200
MDM250M	250
MDM300M	300
MDM350M	350
MDM400M	400
MDM450M	450

Accessories:

Control Cable

PART NO.	DESCRIPTION
RZCAB12	Control Cable 24V - 12M



Replacement Motors

PART NO.	DESCRIPTION
RZM24	24 Volt AC - 2.5Nm
RZM240	240 Volt - 2.5Nm



Exactair Regulators.

Designed to make installation easy.



PIPE INSULATION

CAPPING

UNIT MOUNTING

DRAINAGE

PVC

TAPES AND STRAPS

FLUE

TOOLS

CELDEK PADS

EXACTAIR REGULATORS

EA-BEAR

Big Exact Air Regulator

- Suitable for any large-XL installation
- Up to 6x300 diameter or 3x400 diameter outlets can be fitted
- Easily modified to suit any configuration

Applications:

- Ideal as a supply air starter set for residential ducted split air conditioning units
- Reverse cycle air conditioning
- Evaporative cooling
- Heating
- Ventilation

Compatible Components

PART NO.	DESCRIPTION
BEARBODY	Bear Body
54AD	Adaptor 6 Way to 360
EADAS	Double 150mm Plate
EADASB	6" Neck Plate 1 Hole
EA15A	Exactair 150 Clip in Adaptor
EADA	Double Adaptor
EADAB	Double Adaptor With Blank
EABLANK	Blanking Plate 360 x 180mm
EAMDA	Manual Damper Handle
CABLES	
CABLE6BEIGE	Cable Beige 6M
CABLE12BEIGE	Cable Beige 12M
CABLE25BEIGE	Cable Beige 25M
ZONE MOTORS	
ADM	Black 240V 2.5Nm
CLIP24	Grey 24V 2.5Nm
BLADES	
HALFBLADE	Half Blade
FULLBLADE	Full Blade



Max Dimensions W: 951 - L: 765 - H: 435

INLETS

SMALLEST	LARGEST
200	550

OUTLETS

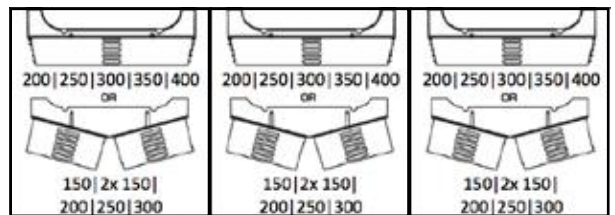

PART NO.	DIMENSIONS (mm)
ADAPTORS	
N2020	375 x 195 - 200
N2025	375 x 195 - 250
N2030	375 x 195 - 300
N3020	295 x 295 - 200
N3025	295 x 295 - 250
N4030	360 x 360 - 300
N4035	360 x 360 - 350
N4040	360 x 360 - 400
N5445	555 x 375 - 450
N5450	555 x 375 - 500
N5455	555 x 375 - 550
TBAD	360 x 360 - 280 x 280

EA-BEAR BUILD SHEET

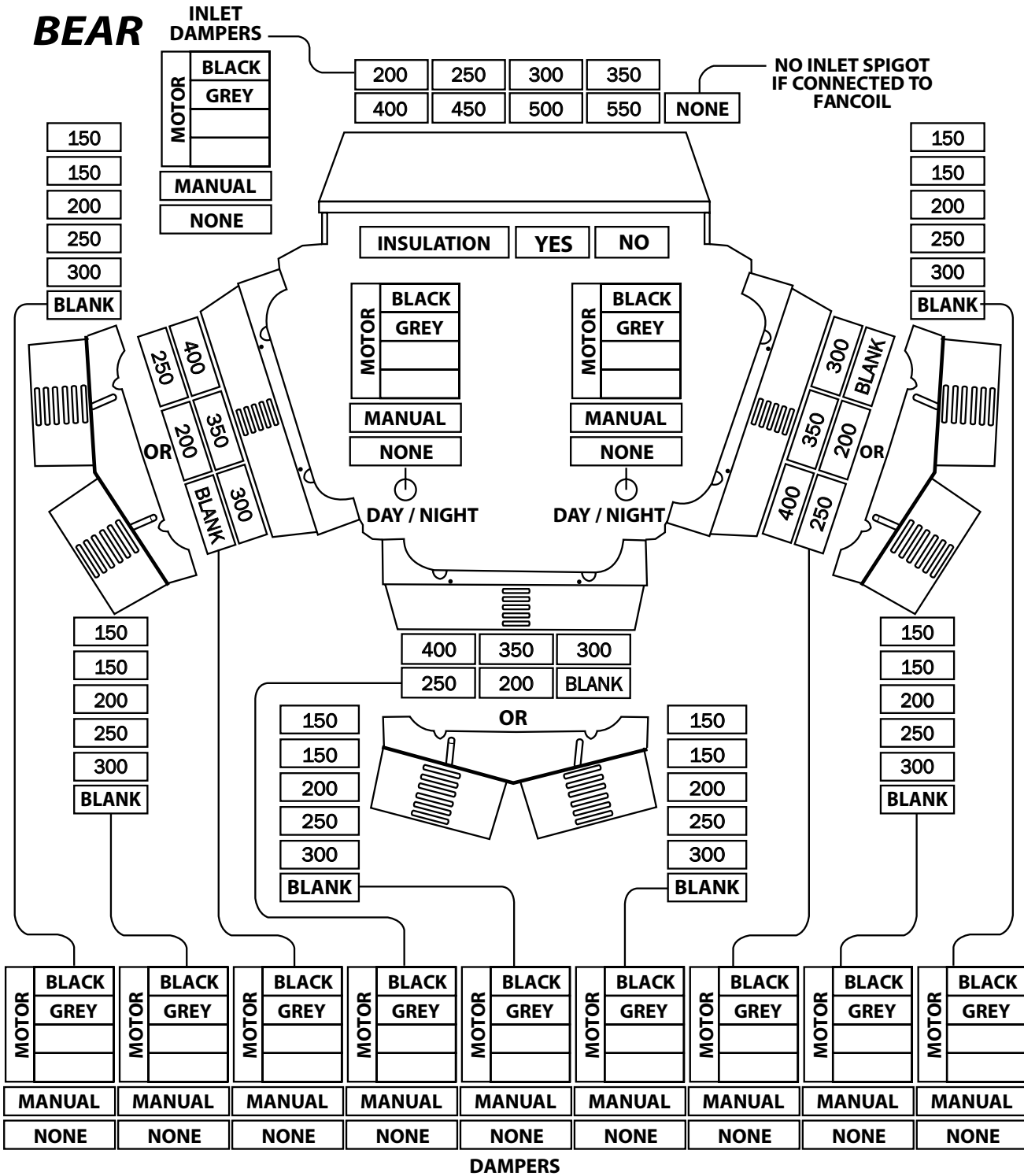

PIPE INSULATION

CAPPING

UNIT MOUNTING

DRAINAGE

PVC

TAPES AND STRAPS

FLUE

TOOLS

CELDEK PADS

EXACTAIR REGULATORS

EA-LEAR

Large Exact Air Regulator

- Suitable for any large installation
- Up to 2x550 diameter outlets can be fitted
- Easily modified to suit any configuration

Applications:

- Ideal as a supply air starter set for residential ducted split air conditioning units
- Reverse cycle air conditioning
- Evaporative cooling
- Heating
- Ventilation



Max Dimensions W: 840 - L: 730 - H: 435

Compatible Components

PART NO.	DIMENSIONS (mm)
LEARBODY	Large Body
54AD	Adaptor 6 Way to 360
EADAS	Double 150mm Plate
EADASB	6" Neck Plate 1 Hole
EA15A	Exactair 150 Clip in Adaptor
EADA	Double Adaptor
EADAB	Double Adaptor With Blank
EABLANK	Blanking Plate 360 x 180mm
EAMDA	Manual Damper Handle
CABLES	
CABLE6BEIGE	Cable Beige 6M
CABLE12BEIGE	Cable Beige 12M
CABLE25BEIGE	Cable Beige 25M
ZONE MOTORS	
ADM	Black 240V 2.5Nm
CLIP24	Grey 24V 2.5Nm
BLADES	
HALFBLADE	Half Blade
FULLBLADE	Full Blade

INLETS

SMALLEST	LARGEST
200	550

OUTLETS

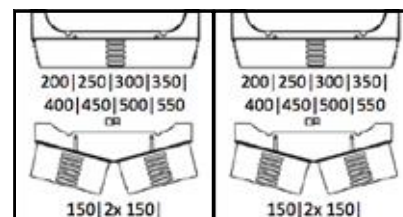

PART NO.	DIMENSIONS (mm)
ADAPTORS	
N2020	375 x 195 - 200
N2025	375 x 195 - 250
N2030	375 x 195 - 300
N3020	295 x 295 - 200
N3025	295 x 295 - 250
N4030	360 x 360 - 300
N4035	360 x 360 - 350
N4040	360 x 360 - 400
N5445	555 x 375 - 450
N5450	555 x 375 - 500
N5455	555 x 375 - 550
TBAD	360 x 360 - 280 x 280

EA-LEAR BUILD SHEET

LEAR

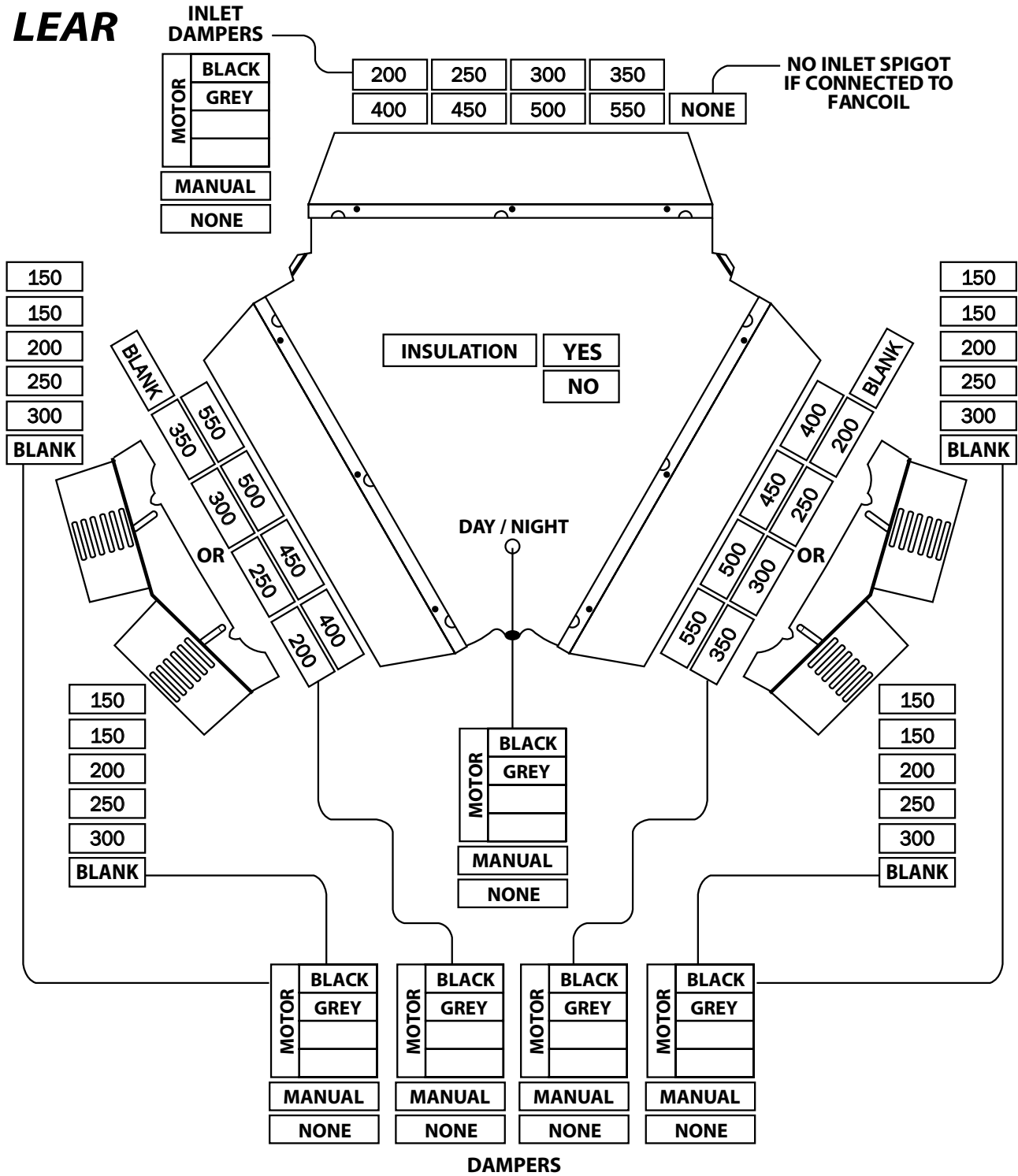

EXACTAIR REGULATORS

EA-FEAR

Final Exact Air Regulator

- Suitable for any medium - large installation
- Up to 4 outlets can be fitted
- Easily modified to suit any configuration

Applications:

- Ideal as a supply air starter set for residential ducted split air conditioning units
- Reverse cycle air conditioning
- Evaporative cooling
- Heating
- Ventilation

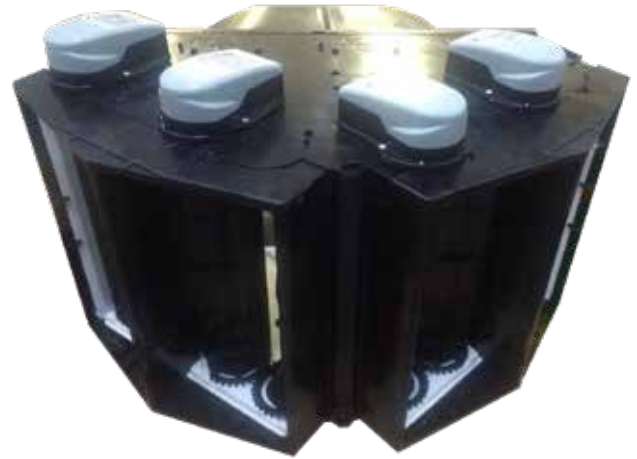

Max Dimensions W: 815 - L: 558 - H: 435

Compatible Components

PART NO.	DESCRIPTION
FEARBODY	Final Body
54AD	Adaptor 6 Way to 360
EADAS	Double 150mm Plate
EADASB	6" Neck Plate 1 Hole
EA15A	Exactair 150 Clip in Adaptor
EADA	Double Adaptor
EADAB	Double Adaptor With Blank
EABLANK	Blanking Plate 360 x 180mm
EAMDA	Manual Damper Handle
CABLES	
CABLE6BEIGE	Cable Beige 6M
CABLE12BEIGE	Cable Beige 12M
CABLE25BEIGE	Cable Beige 25M
ZONE MOTORS	
ADM	Black 240V 2.5Nm
CLIP24	Grey 24V 2.5Nm
BLADES	
HALFBLADE	Half Blade
FULLBLADE	Full Blade

INLETS

SMALLEST	LARGEST
200	550

OUTLETS

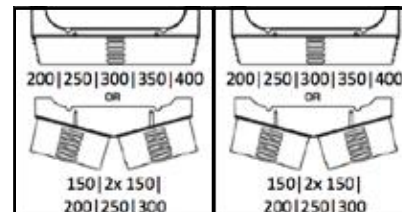

PART NO.	DIMENSIONS (mm)
ADAPTORS	
N2020	375 x 195 - 200
N2025	375 x 195 - 250
N2030	375 x 195 - 300
N3020	295 x 295 - 200
N3025	295 x 295 - 250
N4030	360 x 360 - 300
N4035	360 x 360 - 350
N4040	360 x 360 - 400
N5445	555 x 375 - 450
N5450	555 x 375 - 500
N5455	555 x 375 - 550
TBAD	360 x 360 - 280 x 280

EA-FEAR BUILD SHEET

FEAR

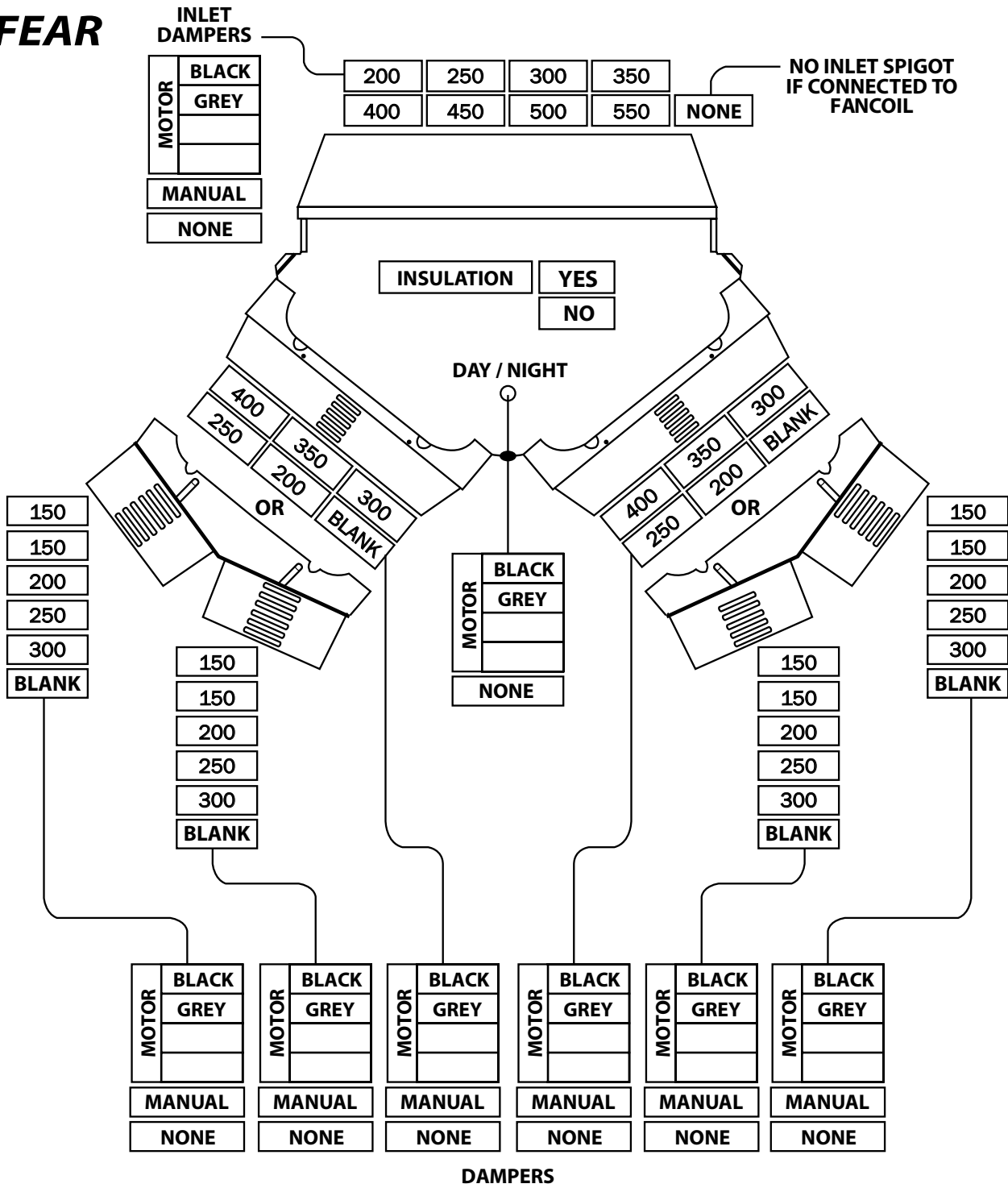

EXACTAIR REGULATORS

EA-SEAR

Small Exact Air Regulator

- Suitable for any small - medium installation
- Up to 4x outlets can be fitted

Applications:

- Ideal as a supply air starter set for residential ducted split air conditioning units
- Reverse cycle air conditioning
- Evaporative cooling
- Heating
- Ventilation



Max Dimensions W: 680 - L: 570 - H: 435

INLETS

SMALLEST	LARGEST
200	400

OUTLETS

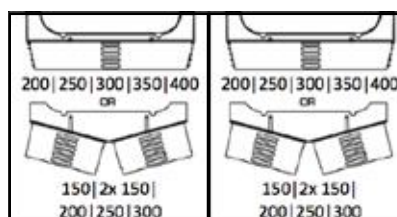

Compatible Components

PART NO.	DESCRIPTION
SEARBODY	Small Body
54AD	Adaptor 6 Way to 360
EADAS	Double 150mm Plate
EADASB	6" Neck Plate 1 Hole
EA15A	Exactair 150 Clip in Adaptor
EADA	Double Adaptor
EADAB	Double Adaptor With Blank
EABLANK	Blanking Plate 360 x 180mm
EAMDA	Manual Damper Handle
CABLES	
CABLE6BEIGE	Cable Beige 6M
CABLE12BEIGE	Cable Beige 12M
CABLE25BEIGE	Cable Beige 25M
ZONE MOTORS	
ADM	Black 240V 2.5Nm
CLIP24	Grey 24V 2.5Nm
BLADES	
HALFBLADE	Half Blade
FULLBLADE	Full Blade

PART NO.	DIMENSIONS (mm)
ADAPTORS	
N2020	375 x 195 - 200
N2025	375 x 195 - 250
N2030	375 x 195 - 300
N3020	295 x 295 - 200
N3025	295 x 295 - 250
N4030	360 x 360 - 300
N4035	360 x 360 - 350
N4040	360 x 360 - 400
TBAD	360 x 360 - 280 x 280

EA-SEAR BUILD SHEET

SEAR

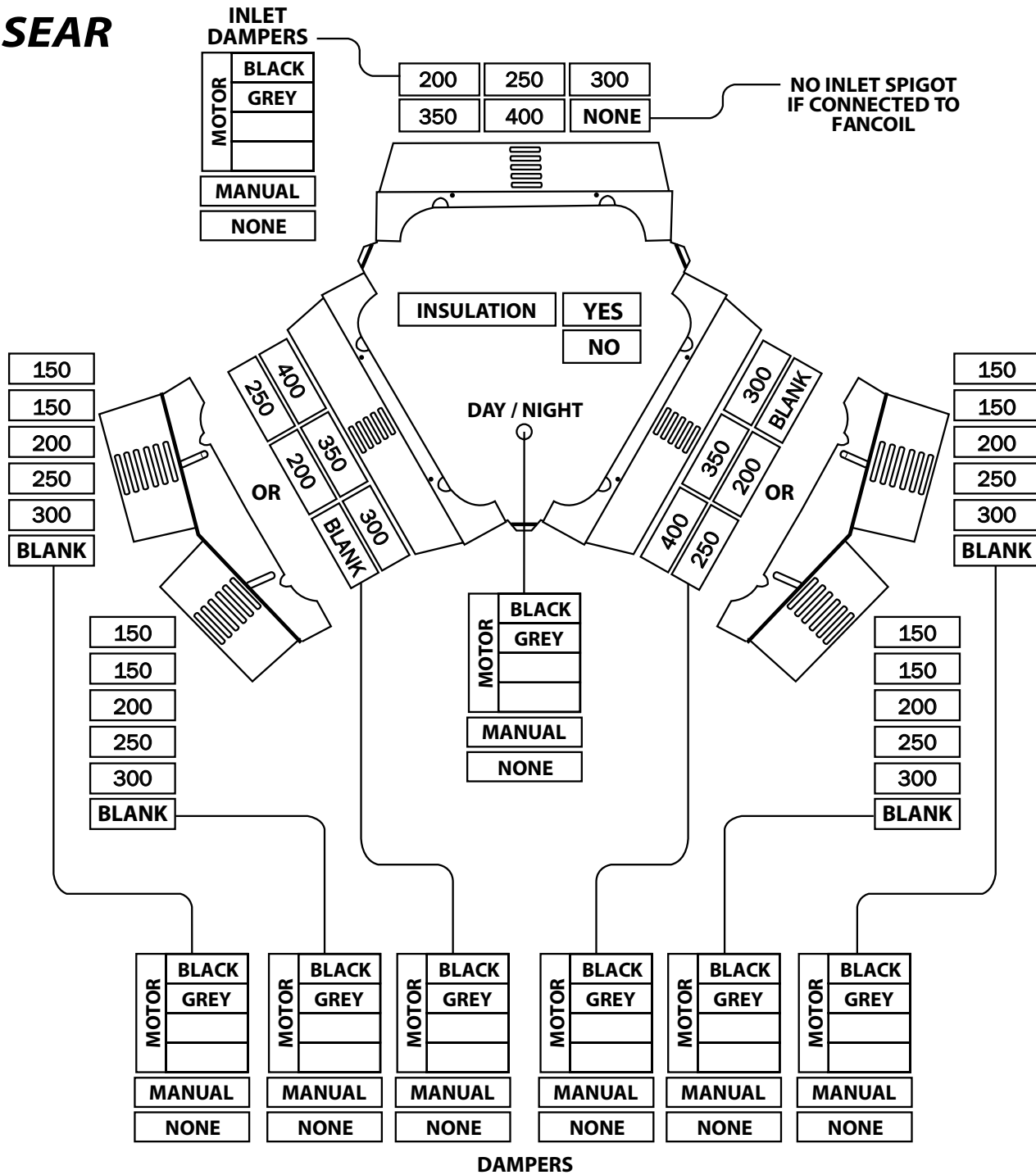

PIPE INSULATION
CAPPING
UNIT MOUNTING
DRAINAGE
PVC
TAPES AND STRAPS
FLUE
TOOLS
CELDEK PADS

EXACTAIR REGULATORS

EA-MEAR

Mini Exact Air Regulator

- Suitable for any small installation
- Up to 2x outlets can be fitted

Applications:

- Ideal as a supply air starter set for residential ducted split air conditioning units
- Reverse cycle air conditioning
- Evaporative cooling
- Heating
- Ventilation



Max Dimensions W: 371 - L: 340 - H: 435

INLETS

SMALLEST	LARGEST
150	400

OUTLETS

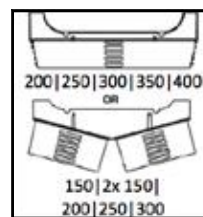

Compatible Components

PART NO.	DESCRIPTION
MEARBODY	Mini Body
54AD	Adaptor 6 Way to 360
EADAS	Double 150mm Plate
EADASB	6" Neck Plate 1 Hole
EA15A	Exactair 150 Clip in Adaptor
EADA	Double Adaptor
EADAB	Double Adaptor With Blank
EABLANK	Blanking Plate 360 x 180mm
EAMDA	Manual Damper Handle
CABLES	
CABLE6BEIGE	Cable Beige 6M
CABLE12BEIGE	Cable Beige 12M
CABLE25BEIGE	Cable Beige 25M
ZONE MOTORS	
ADM	Black 240V 2.5Nm
CLIP24	Grey 24V 2.5Nm
BLADES	
HALFBLADE	Half Blade
FULLBLADE	Full Blade

PART NO.	DIMENSIONS (mm)
ADAPTORS	
N2020	375 x 195 - 200
N2025	375 x 195 - 250
N2030	375 x 195 - 300
N3020	295 x 295 - 200
N3025	295 x 295 - 250
N4030	360 x 360 - 300
N4035	360 x 360 - 350
N4040	360 x 360 - 400
TBAD	360 x 360 - 280 x 280

EA-MEAR BUILD SHEET

MEAR

150	200	250	NONE
300	350	400	

NO INLET SPIGOT
IF CONNECTED TO
FANCOIL

150	200	250	NONE
300	350	400	

OR

150	150
150	150
200	200
250	250
300	300
BLANK	BLANK

MOTOR	BLACK
	GREY
MANUAL	
NONE	

MOTOR	BLACK
	GREY
MANUAL	
NONE	

MOTOR	BLACK
	GREY
MANUAL	
NONE	

DAMPERS

EXACTAIR REGULATORS

EA-CEAR

Compact Exact Air Regulator

- Low profile inline damper
- Easily modified to suit different flexible duct sizes
- Clips into plastic cushion head adaptor
- Suitable for use as a reducer or connector

Applications:

- Ideal as a supply air starter set for residential ducted split air conditioning units
- Reverse cycle air conditioning
- Evaporative cooling
- Heating
- Ventilation



Compatible Components

PART NO.	DESCRIPTION
CEARBODY	Compact Body
EADAS	Double 150mm Plate
EADASB	6" Neck Plate 1 Hole
EA15A	Exactair 150 Clip in Adaptor
EAMDA	Manual Damper Handle
CABLES	
CABLE6BEIGE	Cable Beige 6M
CABLE12BEIGE	Cable Beige 12M
CABLE25BEIGE	Cable Beige 25M
ZONE MOTORS	
ADM	Black 240V 2.5Nm
CLIP24	Grey 24V 2.5Nm
BLADES	
HALFBLADE	Half Blade
FULLBLADE	Full Blade

Max Dimensions W: 145 - L: 381 - H: 200

INLETS

SMALLEST	LARGEST
150	300

OUTLETS

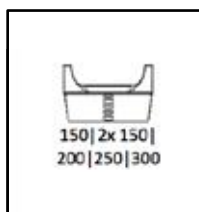

PART NO.	DIMENSIONS (mm)
ADAPTORS	
N2020	375 x 195 - 200
N2025	375 x 195 - 250
N2030	375 x 195 - 300

EA-CEAR BUILD SHEET

CEAR

150	200
250	300

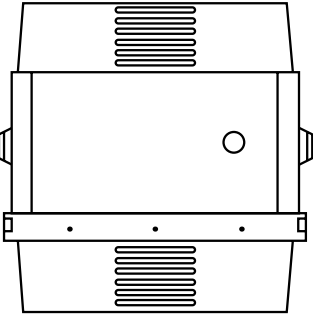

INSULATION

YES

NO

PLASTIC CUSHION HEAD ADAPTOR

OR

150
150
200
250
300

MOTOR	BLACK
	GREY
MANUAL	
NONE	

DAMPERS

NO SPIGOT REQUIRED
IF CONNECTED TO
CUSHION HEAD ADAPTOR

PIPE INSULATION

CAPPING

UNIT MOUNTING

DRAINAGE

PVC

TAPES AND STRAPS

FLUE

TOOLS

CELDEK PADS

SMART TEMP THERMOSTATS



7 DAY PROGRAMABLE

- 24VAC or Battery Powered (2 x AA)
- Large Backlit LCD
- Security Logic inc Key Lock & Limit Control
- 7 day, 5+2 Day or Manual Operation
- Programmable Fan Logic
- Heat Cool & Heat Pump Logic
- Single & Multistage Control
- Remote Sensor Inputs
- Outside Temperature Display



PART NO.	DESCRIPTION
SMT44850	Apollo Touch Screen Thermostat

MULTIFUNCTION THERMOSTAT

- Multifunction Temperature Controller
- 7 Day or Manual Programming
- 3 Fan Speed
- Auto Changeover
- Multistage Outputs
- 24Volt Control
- Remote Sensor Option
- Suitable for Reverse Cycle and Gas Heat/Cool Systems
- Modbus Communication



PART NO.	DESCRIPTION
SMT-770	Chamelon Thermostat

VORTEX DUCT
FITTINGS
TRANSITIONS
ZONE MANAGEMENT
AIR DIFFUSERS AND GRILLES
EVAPORATIVE COOLING
VENTILATION
ELECTRICAL
COPPER

HONEYWELL THERMOSTATS

DIGITAL PROGRAMABLE

- Large, clear, backlit display - easy to read in various lighting conditions
- Precise comfort control maintains consistent comfort to the highest level of accuracy
- Simplified programming and operation
- Easy access battery replacement

PART NO.	DESCRIPTION
TH611OD1021	Focus Pro 6000



UNIVERSAL REMOTE CONTROL

- Compatible with over 10,000 Air Con units
- Clock and timer included

PART NO.	DESCRIPTION
RCU	KT Universal Remote



THERMOSTAT GUARDS

PART NO.	SIZE (mm)
TGS	Small - 162 x 89 x 76
TGM	Medium - 134 x 111 x 76
TGL	Large - 210 x 137 x 89



SMART TEMP ZONING



1-4 ZONE TOUCH PAD

EZC

Description: 1-4 Zone Touch Pad

- 1-4 Zone touch pad
- 24V Powered
- Suitable for 24V Dampers
- RJ12 Socket for Dampers
- Supplied with 4 Overlay labels for Zone Name Selection

Operates separate from the air conditioning controls to provide on/off zoning for up to 4 zones per touch pad



Kit Contains

- Touch Pad
- 4 x 1 to 4 Zone Faced Covers
- 20 x Room Stickers
- Installation Guide

*Requires 24V power supply - P/No: EZTRANS

1-2 ZONE TOUCH PAD

EZC1

Description: 2 Zone Touch Pad

- 2 Zone Wall Panel
- 24V Powered
- Suitable for 24V Dampers
- RJ12 Socket for Dampers
- Supplied with 4 Overlay labels



Operates separate from the air conditioning controls to provide on/off zoning for up to 2 zones per touch pad

Kit Contains

- Touch Pad
- 4 x 1 to 2 Zone Faced Covers

*Requires 24V power supply - P/No: EZTRANS

POWER SUPPLY - 24V

EZTRANS

- 24V AC 2 AMP - 240V input



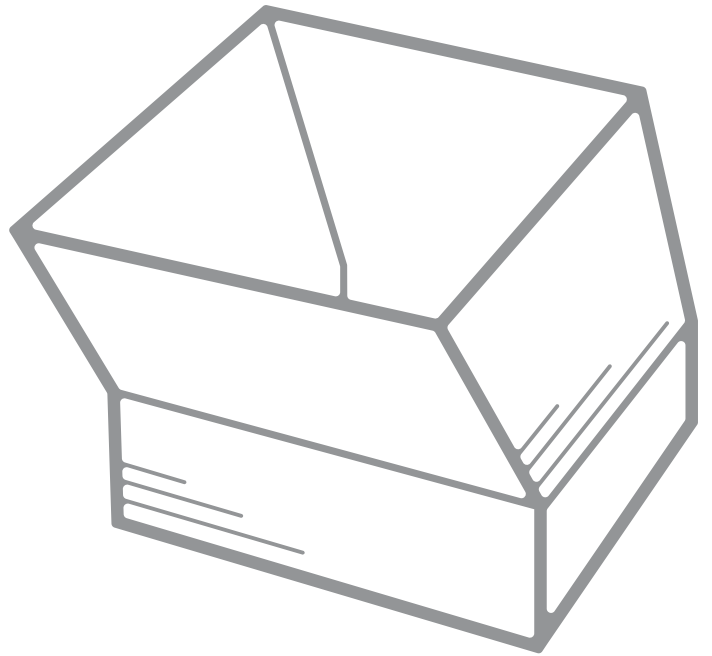

EVAPORATIVE COOLING



WEATHERGUARD

DROPPERS ABS - ANGLED NECK



PART NO.	COLOUR
WGABEIGE	Beige
WGAGREEN	Green
WGAGREY	Grey
WGARED	Red

FLASHING



PART NO.	COLOUR
WGFBEIGE	Beige
WFGREEN	Green
WFGREY	Grey
WGFRED	Red

BRIVIS ADAPTOR

PART NO.	COLOUR
BRIVISADAPTOR	Weatherguard Dropper

AIR CHUTE

- Suits 550 x 550 dropper

PART NO.	OUTLETS
AIRCHUTE	4



METAL FLASHING & DROPPERS COLORCOTE®

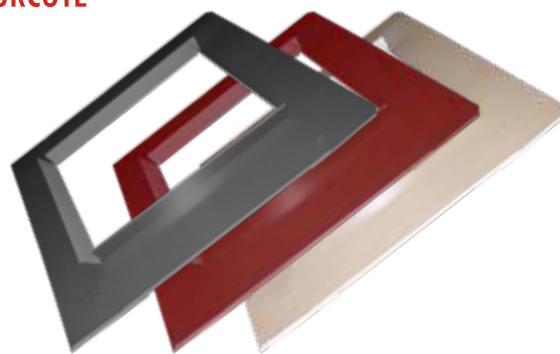

DROPPERS

PART NO.	COLOUR
550 x 550 - 1200	
DC55BEIGE	Stone Beige
DC55CHOC	Chocolate Jasper
DC55GREEN	Wilderness Green
DC55GREY	Woodland Grey
DC55RED	Manor Red
DG55	Galvanised
550 x 800 - 1200	
DC85BEIGE	Stone Beige
DC85GREY	Woodland Grey
DC85RED	Manor Red
550 x 550 - 900	
DCBBEIGE	Stone Beige
DCBGREY	Woodland Grey
DCBRED	Manor Red

BASES - GALVANISED

PART NO.	COLOUR
BASE550	550 x 550
BASE800	550 x 800

FLASHING

PART NO.	COLOUR
550 x 550	
FC55BEIGE	Stone Beige
FC55CHOC	Chocolate Jasper
FC55GREEN	Wilderness Green
FC55GREY	Woodland Grey
FC55RED	Manor Red
FG55	Galvanised
550 x 800	
FC85BEIGE	Stone Beige
FC85GREY	Woodland Grey
FC85RED	Manor Red
TIN ROOF	
550 x 550	
FC55BEIGETIN	Stone Beige
FC55CHOCTIN	Chocolate Jasper
FC55GREENTIN	Wilderness Green
FC55GREYTIN	Woodland Grey
FC55REDTIN	Manor Red
FG55TIN	Galvanised



PLASTIC PLENUMS & PUMPS

SQUARE PLENUMS & PLATES

PART NO.	SUITS	SIZE (mm)
ACP1	PP1	780 x 780 x 170
PP1	ACP1	-



HEXAGON PLENUMS & PLATES

PART NO.	SUITS	SIZE (mm)
ACP3	PP3	960 x 960 x 310
PP3	ACP3	-

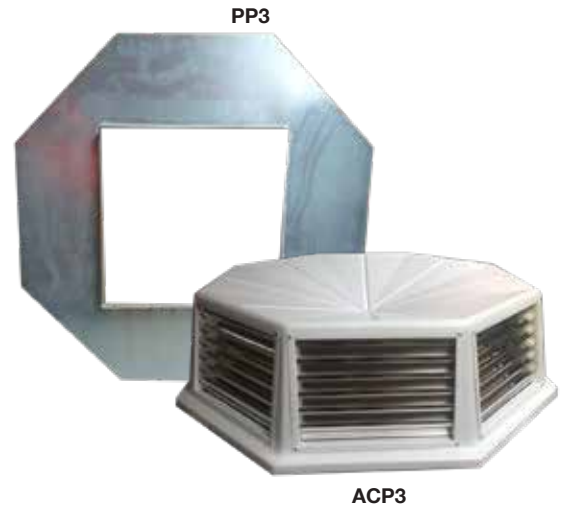

PUMPS

PART NO.	DESCRIPTION
EP28	Cooler Pump 24Lpm
EP38	Cooler Pump 29.5Lpm
EP50	Cooler Pump 38Lpm



VORTEX DUCT
 FITTINGS
 TRANSITIONS
 ZONE MANAGEMENT
 AIR DIFFUSERS AND GRILLES
 EVAPORATIVE COOLING
 VENTILATION
 ELECTRICAL
 COPPER

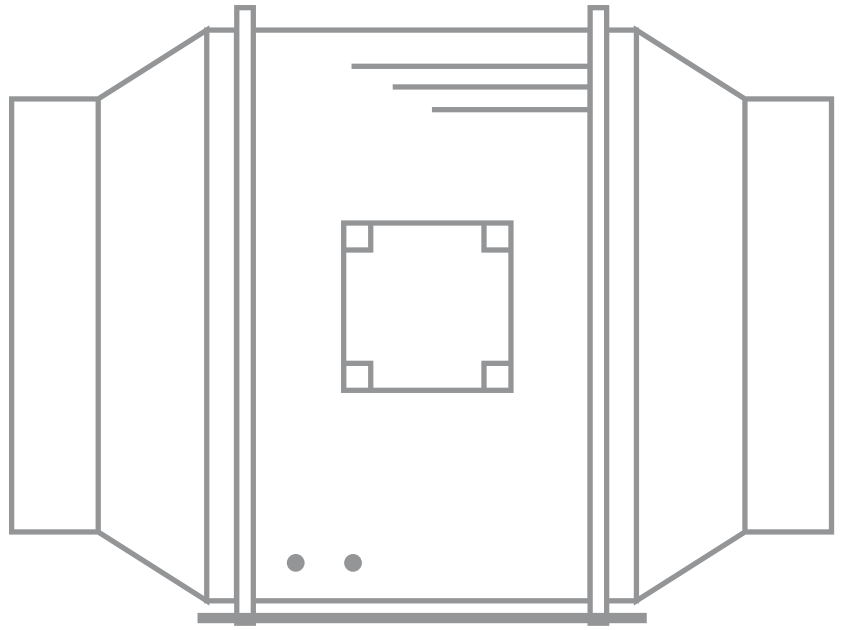

VENTILATION



MIX FLOW FANS

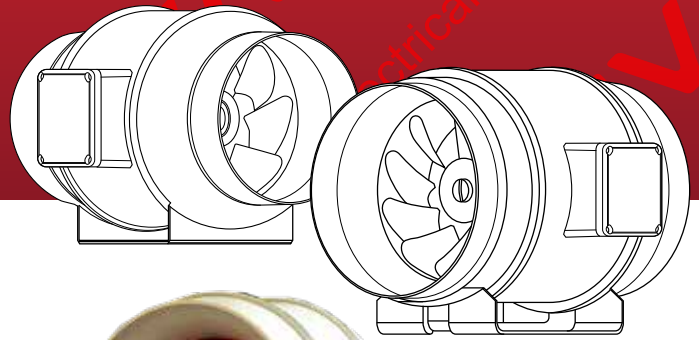

MIX FLOW FANS



- Externally mounted 2 speed switch
- High air pressure
- Low noise
- Low power
- Large volume

PART NO.	SIZE (mm)
RX100	100
RX125	125
RX150	150
RX200	200
RX250	250
RX315	315

Performance Specs

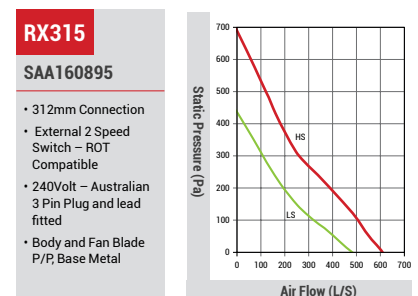
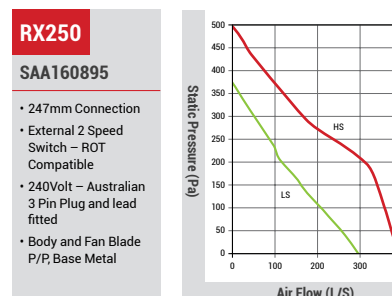
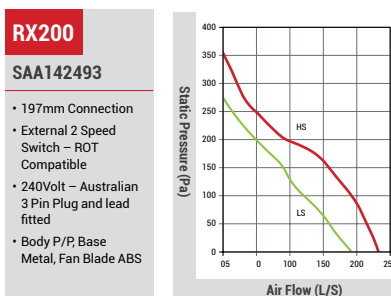
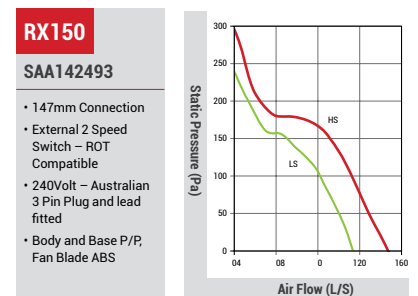
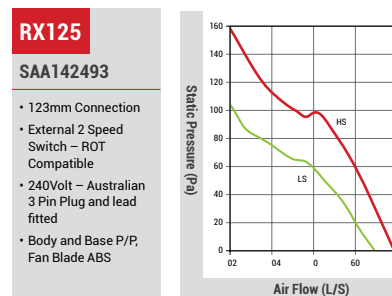
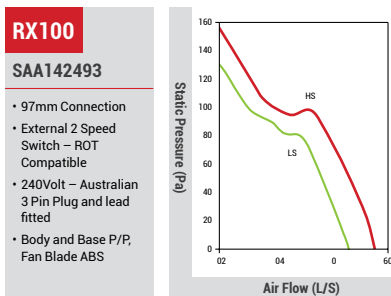

Performance Data

SPECIFICATIONS	RX100		RX125		RX150		RX200		RX250		RX315	
	Low	High	Low	High	Low	High	Low	High	Low	High	Low	High
Speed (RPM)	1850	2200	1850	2250	1850	2550	1950	2450	1850	2450	1650	2350
Airflow (m³/h)	165	198	248	284	410	530	690	840	1064	1405	1750	2206
Airflow (l/s)	46	55	69	79	114	147	192	233	296	390	474	613
Air Pressure (Pa)	131	156	106	159	240	300	274	352	371	488	435	693
Noise (dB) @3m	26	31	26	31	29	33	55	63	58	66	61	69
Current (Amps)	0.11	0.12	0.13	0.14	0.19	0.22	0.52	0.53	0.75	1.2	1.4	1.9
Power (W)	23	26	28	33	44	54	123	128	165	225	275	390
Operating Temp	-20°C ~ 60°C											
Voltage / Frequency	220 ~ 240V / 50Hz											
IP Rating	IP44											
Length mm (L)	302		257		313		302		383		446	
Width mm (W)	204		204		227		249		310		386	
Height mm (H)	195		195		208		237		286		357	
Pop mm (P)	97		123		147		197		247		312	

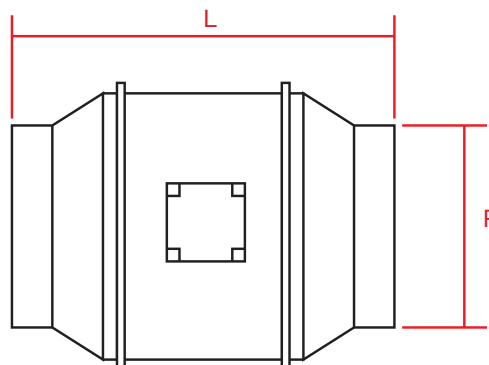
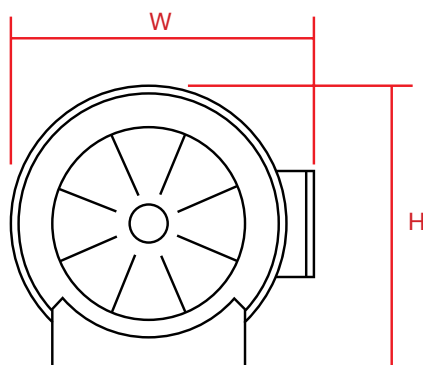

MIX FLOW FANS

Mounting and Dismounting



Easy mount and Dismount.

The support bracket allows the central fan body to be fitted or removed without dismantling the ductwork.

- Remove body to install bracket.

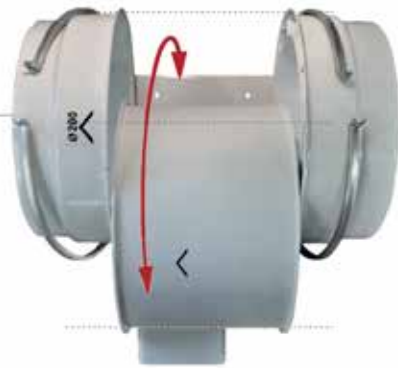

Align fan body with arrow flow direction.

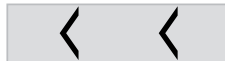

Installation Components



Flexible Duct - Nude



Non Return Damper

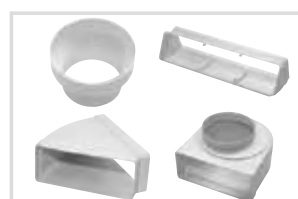

Low Profile Duct



Vent Grilles

3 ZERO - NUDE CORE - 6M

PART NO.	SIZE (mm)
NC64	100
NC65	125
NC66	150
NC68	200
NC610	250
NC612	300
NC614	350

4 ZERO - NUDE CORE - 6M

PART NO.	SIZE (mm)
4ZNC5	125
4ZNC6	150
4ZNC8	200



GRILLES

select range

SQUARE EGGCRATES

PART NO.	SIZE (mm)
ECA150	150
ECA200	200



ROUND EGGCRATES

PART NO.	SIZE (mm)
ECR150	150
ECR200	200



FIXED LOUVRES

PART NO.	SIZE (mm)
FLG100	100
FLG125	125
FLG150	150



GRAVITY LOUVRES

PART NO.	SIZE (mm)
GLG100	100
GLG125	125
GLG150	150



PIPE INSULATION

CAPPING

UNIT MOUNTING

DRAINAGE

PVC

TAPES AND STRAPS

FLUE

TOOLS

CELDEK PADS

LOW PROFILE DUCT

LOW PROFILE DUCT

- Compatible with AAD's RX mixed flow fans
- Save on joiners / cost saving
- Allows higher ceilings in apartments
- Channel duct comes in 2m length
- Used in limited ceiling space
- Brackets can be fixed using ramset charges thus reducing installation time
- Maximises fan performance due to less resistance
- Fire resistant

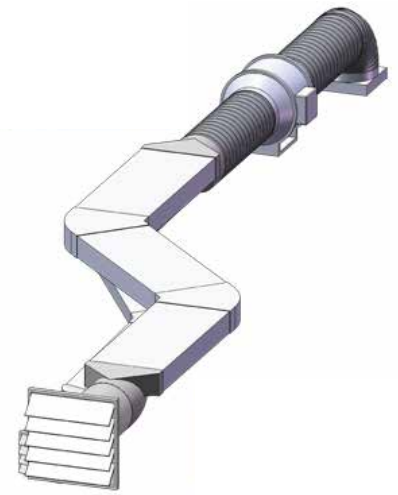

DESCRIPTION	220 x 90	350 x 75
2M Rectangle Duct	LDP22902M	LDP35752M
45° Vertical Bend	LDP22045VB	LDP35045VB
90° Vertical Bend	LDP22090VB	LDP35090VB
45° Horizontal Bend	LDP22045HB	LDP35045HB
90° Horizontal Bend	LDP22090HB	LDP35090HB
Connector	LDP220DUCON	LDP350DUCON
Round to Round Adaptor (150-125mm)	LDP220R2R15	-
Round to Round Adaptor (200-150mm)	LDP220R2R20	-
Rangehood Adaptor	LDP220RANGE	LDP350RANGE
Round to Rectangle Adaptor (220-150mm)	LDP220RTREC200	LDP350RTREC150 (350-150mm)
Round to Rectangle Adaptor (220-200mm)	LDP220RTREC150	LDP350RTREC200 (350-200mm)
T Piece	LDP220TP	LDP350TP
90° Elbow (125mm)	LDP125R90E	-
Duct Clip	LDP220CLIP	LDP350CLIP



ROOF COWLS & KITS



ROOF COWL SET

- General purpose cowl kit
- 0.5 HDPE tube included
- Dektite included (for metal based roofs)
- Optional lead roof flashing available at extra cost

PART NO.	SIZE (mm)
SECD0172	150

ROOF FAN KIT

- Axial fan incorporated in a cowl
- Aluminium cowl construction
- High quality for longevity
- Electrical connection can be made inside or outside roof space (Interior junction box included)
- Low noise within premises
- Dektite included (for metal based roofs)
- L/S = 80

PART NO.	SIZE (mm)
SEC0532	150

ROOF FAN KIT - CENTRIFUGAL

- Centrifugal fan incorporated in a cowl
- Aluminium cowl construction
- High quality for longevity
- Electrical connection can be made inside or outside roof space (Interior junction box included)
- Low noise within premises
- Dektite included (for metal based roofs)
- L/S = 130

PART NO.	SIZE (mm)
SEC0530	150

NON RETURN DAMPERS

PART NO.	SIZE (mm)
NRD150	150
NRD200	200
NRD250	250



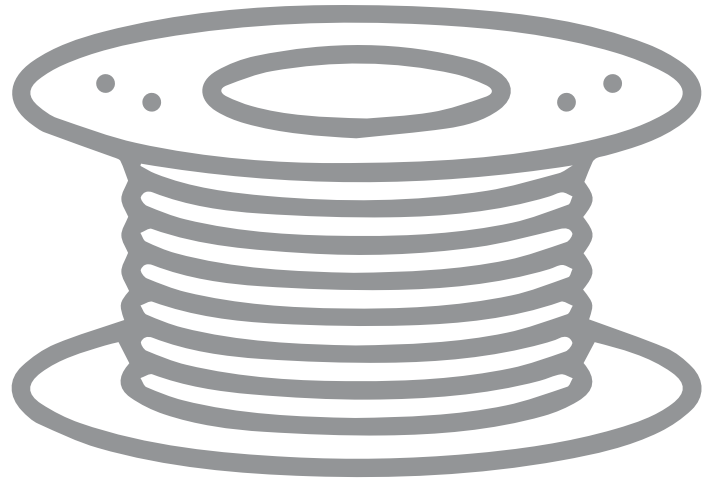

ELECTRICAL



CABLES & TIES

CABLE

PART NO.	DESCRIPTION
CONTROLLER CABLE	
FIG8	Clear PVC 2 Core .75mm 32V AC or 100V DC - 100M
SINGLE CORE - ROUND WHITE SHEATH	
CAB1-5SDI	Red 1.5mm Round 450/750V - 100M
TWIN CORE - FLAT WHITE SHEATH	
CAB1-5TWIN	Red/White 1.5mm 450/750V - 100M
TWIN CORE - EARTH - FLAT WHITE SHEATH	
1.5mm	
CAB1-5TCE	Red/Black-Green 1.5mm 450/750V - 100M
2.5mm	
CAB2-5TCE	Red/Black-Green 2.5mm 450/750V - 100M



CABLE TIES

PART NO.	COLOUR	SIZE (mm)
CTIEW	White	200
CTIEB	Black	200



DUCT TIES

PART NO.	SIZE (mm)
DT1200 DT1200/100	1200 x 9



ISOLATING SWITCH - WEATHERPROOF

- IP 66

PART NO.	DESCRIPTION
UKF120	1P 20A - 250V
UKF135	1P 35A - 250V
UKF220	2P 20A - 440V
UKF335	3P 35A - 500V
MINI ISOLATOR	
FDS120	1P 20A - 250V



POWER OUTLET - WEATHERPROOF

- IP 53, 250V

PART NO.	DESCRIPTION
FD56S110H	1 Outlet 10A
FD56S210	2 Outlet 10A



RCBO

- Residual current operated circuit breaker
- 30mA, 240V, 6K
- Overcurrent protection
- ESV approved

PART NO.	DESCRIPTION
DL7NL4010	1P+N 10A
DL7NL4016	1P+N 16A
DL7NL4020	1P+N 20A
DL7NL4025	1P+N 25A



JUNCTION BOX

PART NO.	DESCRIPTION
FDTX001	Small - 81 x 61 x 40mm
FDTX002	Large - 100 x 65 x 48mm



ELECTRICAL ACCESSORIES

CONDUIT

MORRISON

PART NO.	DESCRIPTION	SIZE (mm)
FLEXIBLE		
MCC2020	Medium Duty - Grey	20mm - 20M
MCC2520	Medium Duty - Grey	25mm - 20M
CON2020	BEP Medium Duty - Grey	20mm - 20M
CON2520	BEP Medium Duty - Grey	25mm - 20M
RIGID		
RC20G	Medium Duty UPVC	20mm - 4M
RC25G	Medium Duty UPVC	25mm - 4M



ACCESSORIES

PART NO.	DESCRIPTION	SIZE (mm)
CSCT20 FD32020	Clip Adaptor with Ring	20
CSCT25 FD32025	Clip Adaptor with Ring	25
ST20 FD12020	Straight Tee	20
ST25 FD12025	Straight Tee	25
EL20 FD10020	Solid Elbow 90°	20
EL25 FD10025	Solid Elbow 90°	25
SO20 FD05020	Solid Coupling	20
SO25 FD05025	Solid Coupling	25
FDMB1220	Full Saddle	20
FDMB1225	Full Saddle	25
FDMB1120	Half Saddle	20
FDMB1125	Half Saddle	25
JB220 FDJB202	2 Way Junction Box	20
JB225 FDJB252	2 Way Junction Box	25



New part numbers arriving later 2019



COPPER



COPPER

PAIR COIL

- R410A rated



PART NO.	SIZE (mm)	SIZE (inch)
20M Roll		
PC1438	6.35 - 9.52	1/4" - 3/8"
PC1412	6.35 - 12.7	1/4" - 1/2"
PC1458	6.35 - 15.88	1/4" - 5/8"
PC3858	9.52 - 15.88	3/8" - 5/8"
PC3834	9.52 - 19.05	3/8" - 3/4"
10M Roll		
PC103858	9.52 - 15.88	3/8" - 5/8"
5M Roll		
PC51438	6.35 - 9.52	1/4" - 3/8"
PC51438	6.35 - 12.7	1/4" - 1/2"
PC51458	6.35 - 15.88	1/4" - 5/8"
PC53858	9.52 - 15.88	3/8" - 5/8"

SOFT DRAWN PANCAKE

- R410A rated



PART NO.	SIZE (mm)	SIZE (inch)
CR14	6.35 - 30M	1/4" - 30M
CR38	9.52 - 18M	3/8" - 18M
CR12	12.70 - 18M	1/2" - 18M
CR58	15.88 - 18M	5/8" - 18M
CR34	19.05 - 18M	3/4" - 18M
CR78	22.23 - 18M	7/8" - 18M

PAIR COIL - FIRE RATED

- R410A rated



PART NO.	SIZE (mm)	SIZE (inch)
FIRE RATED 13mm - 20M Roll		
FR1438-13	6.35 - 9.52	1/4" - 3/8"
FR1412-13	6.35 - 12.7	1/4" - 1/2"
FR1458-13	6.35 - 15.88	1/4" - 5/8"
FR3858-13	9.52 - 15.88	3/8" - 5/8"
FIRE RATED 19mm - 18M Roll		
FR1438-19	6.35 - 9.52	1/4" - 3/8"
FR1412-19	6.35 - 12.7	1/4" - 1/2"
FR1458-19	6.35 - 15.88	1/4" - 5/8"
FR3858-19	9.52 - 15.88	3/8" - 5/8"

HARD DRAWN

- R410A rated
- 6M lengths



PART NO.	SIZE (mm)	SIZE (inch)
HD14	6.35	1/4"
HD38	9.52	3/8"
HD12	12.70	1/2"
HD58	15.88	5/8"
HD34	19.05	3/4"
HD78	22.23	7/8"
HD1	25.40	1"
HD118	28.60	1 - 1/8"
HD138	34.92	1 - 3/8"
HD158	41.28	1 - 5/8"

ACCESSORIES

ARADON

ELBOWS 90°

- R410A rated
- Sold in bags of:



PART NO.	SIZE (mm)	SIZE (inch)	BAG QTY
ELB90014	6.35	1/4"	10
ELB90038	9.52	3/8"	10
ELB90012	12.70	1/2"	10
ELB90058	15.88	5/8"	10
ELB90034	19.05	3/4"	5
ELB90078	22.23	7/8"	5
ELB90010	25.40	1"	2
ELB90118	28.60	1 - 1/8"	2

ELBOWS 45°

- R410A rated
- Sold in bags of:



PART NO.	SIZE (mm)	SIZE (inch)	BAG QTY
ELB45014	6.35	1/4"	10
ELB45038	9.52	3/8"	10
ELB45012	12.70	1/2"	10
ELB45058	15.88	5/8"	10
ELB45034	19.05	3/4"	5
ELB45078	22.23	7/8"	5
ELB45010	25.40	1"	2
ELB45118	28.60	1 - 1/8"	2

SOCKETS

- R410A rated
- Sold in bags of:



PART NO.	SIZE (mm)	SIZE (inch)	BAG QTY
SOK014	6.35	1/4"	10
SOK038	9.52	3/8"	10
SOK012	12.70	1/2"	10
SOK058	15.88	5/8"	10
SOK034	19.05	3/4"	5
SOK078	22.23	7/8"	5
SOK010	25.40	1"	2
SOK118	28.60	1 - 1/8"	2

ACCESSORIES

T JOINTS

- R410A rated
- Sold in bags of:

ARADON

PART NO.	SIZE (mm)	SIZE (inch)	BAG QTY
TEE012	12.70	1/2"	5
TEE034	19.05	3/4"	5



GAS COCKS

- Gas Cock Compression AGA Approved

PART NO.	SIZE (mm)	SIZE (inch)
GC15	15	1/2"
GC20	20	3/4"



BALL VALVES

- Ball Valves are Fi X Fi Dual Approved

PART NO.	SIZE (mm)	SIZE (inch)
BV15	15	1/2"
BV20	20	3/4"



PIPE INSULATION

CAPPING

UNIT MOUNTING

DRAINAGE

PVC

TAPES AND STRAPS

FLUE

TOOLS

CELDEK PADS

FLAME-FREE FITTINGS



The ZoomLock Advantage

- High Pressure HVAC/R
- Continuous operating temperature 120°
- MRP = 700 psi / 48 bar
- Max Burst Pressure UL 207 = 2100 psi / 145 bar
- Vibration Resistance conforms to ULD 109
- 5 Year Warranty from date of install

ZOOMLOCK TOOL KIT

Kit Includes:

- ✓ 19kN ZoomLock™ Crimping Tool (1 3/8" capacity)
- ✓ Tube Cutter
- ✓ Deburring Tool
- ✓ Crimp Gauge
- ✓ Depth Gauge
- ✓ Stainless Steel Brush
- ✓ Abrasive Pad
- ✓ Permanent Marker



KLAUKE JAWS

- R410A rated
- Individually sold



PART NO.	SIZE (mm)	SIZE (inch)
770230	6.6	1/4"
770232	9.8	3/8"
770233	13.0	1/2"
770234	16.1	5/8"
770235	19.3	3/4"
770236	22.5	7/8"
770237	28.8	1 1/8"
770238	34.9	1 3/8"
770241	25.7	1"

FLAME-FREE FITTINGS



COUPLINGS

- R410A rated
- Individually sold



PART NO.	SIZE (mm)	SIZE (inch)
770500	6.6	1/4"
770502	9.8	3/8"
770503	13.0	1/2"
770504	16.1	5/8"
770505	19.3	3/4"
770506	22.5	7/8"
770513	25.7	1"
770507	28.8	1 - 1/8"

REDUCERS

- R410A rated
- Individually sold



PART NO.	SIZE (mm)	SIZE (inch)
770800	9.8 - 6.6	3/8" - 1/4"
770808	13.0 - 6.6	1/2" - 1/4"
770801	13.0 - 9.8	1/2" - 3/8"
770809	16.1 - 6.6	5/8" - 1/4"
770810	16.1 - 9.8	5/8" - 3/8"
770802	16.1 - 13.0	5/8" - 1/2"
770811	19.3 - 13.0	3/4" - 1/2"
770803	19.3 - 16.1	3/4" - 5/8"
770812	22.5 - 13.0	7/8" - 1/2"
770804	22.5 - 16.1	7/8" - 5/8"
770805	22.5 - 19.3	7/8" - 3/4"
770823	25.7 - 22.5	1" - 7/8"
770813	28.8 - 13.0	1 1/8" - 1/2"
770814	28.8 - 16.1	1 1/8" - 5/8"
770806	28.8 - 19.3	1 1/8" - 3/4"
770807	28.8 - 22.5	1 1/8" - 7/8"
770818	34.9 - 22.5	1 3/8" - 7/8"
770819	34.9 - 28.8	1 3/8" - 1 1/8"

FLAME-FREE FITTINGS



ELBOWS 45°

- R410A rated
- Individually sold



PART NO.	SIZE (mm)	SIZE (inch)
771402	9.8	3/8"
771403	13.0	1/2"
771404	16.1	5/8"
771405	19.3	3/4"
771406	22.5	7/8"
771407	28.8	1 - 1/8"
771408	35.2	1 - 3/8"

ELBOWS 90°

- R410A rated
- Individually sold
- Long radius



PART NO.	SIZE (mm)	SIZE (inch)
770600	6.6	1/4"
770602	9.8	3/8"
770603	13.0	1/2"
770604	16.1	5/8"
770605	19.3	3/4"
770606	22.5	7/8"
770610	25.7	1"
770607	28.8	1 - 1/8"
770608	35.2	1 - 3/8"

TEES

- R410A rated
- Individually sold



PART NO.	SIZE (mm)	SIZE (inch)
770702	9.8	3/8"
770703	13.0	1/2"
770704	16.1	5/8"
770705	19.3	3/4"
770706	22.5	7/8"
770707	28.8	1 - 1/8"
770708	35.3	1 - 3/8"

VORTEX DUCT

FITTINGS

TRANSITIONS

ZONE MANAGEMENT

AIR DIFFUSERS AND GRILLES

EVAPORATIVE COOLING

VENTILATION

ELECTRICAL

COPPER



FLAME-FREE FITTINGS

SAE FLARE

- R410A rated
- Individually sold



PART NO.	SIZE (mm)	SIZE (inch)
771000	6.6	1/4"
771002	9.8	3/8"
771003	13.0	1/2"
771004	16.1	5/8"
771005	19.3	3/4"

Y-JOINTS

- R410A rated
- Individually sold

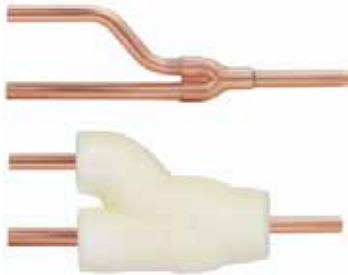

PART NO.	SIZE (mm)	SIZE (inch)
771102	9.8	3/8"
771103	13.0	1/2"
771104	16.1	5/8"
771105	19.3	3/4"
771106	22.5	7/8"
771107	28.8	1 - 1/8"

3 reasons to choose ZoomLock



1. NO HOT WORKS

ZoomLock is a flame-free joining system, No flame or gas required. Removing fire risk completely.



2. SAVINGS

No more oxy/acetylene.
No more purging with nitrogen.
No more solder.



3. FASTER PROJECTS

Known as the "10 second leak proof refrigerant fitting"

PIPE INSULATION
CAPPING
UNIT MOUNTING
DRAINAGE
PVC
TAPES AND STRAPS
FLUE
TOOLS
CELDEK PADS

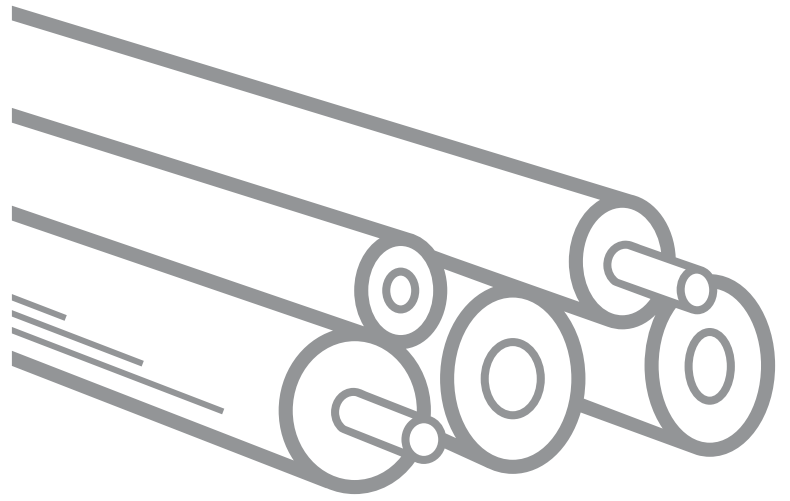

PIPE INSULATION



PIPE INSULATION

PIPE INSULATION

- 2M lengths

Applications

- Heating
- Airconditioning
- Plumbing
- Refrigeration
- Solar Energy

Fire Rated

- Tested to AS1530.3
- No Flame Spread
- Non Drip
- Low Smoke
- Density 60-75kg / m³
- Operating Temperature -40° C / +105° C



PART NO.	SIZE (mm)	SIZE (inch)
9mm Wall		
I14	6	1/4"
I38	10	3/8"
I12	13	1/2"
I58	15	5/8"
I34	20	3/4"
I78	22	7/8"
I1	25	1"
I118	28	1 - 1/8"
13mm Wall		
I1310	10	3/8"
I1312	13	1/2"
I1315	15	5/8"
I1320	20	3/4"
I1322	22	7/8"
I1325	25	1"
I1328	28	1 - 1/8"
19mm Wall		
I1906	6	1/4"
I1910	10	3/8"
I1912	13	1/2"
I1915	15	5/8"
I1920	20	3/4"
I1922	22	7/8"
I1925	25	1"
I1928	28	1 - 1/8"

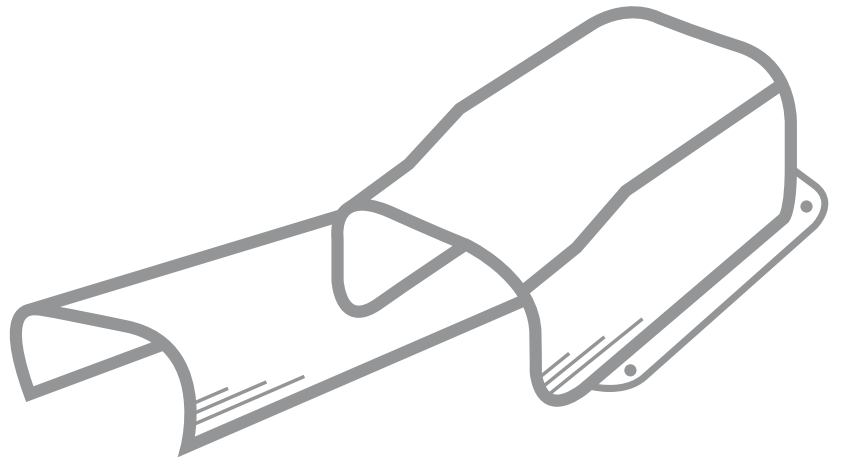

CAPPING



METAL CAPPING

METAL CAPPING

- 2.4M lengths

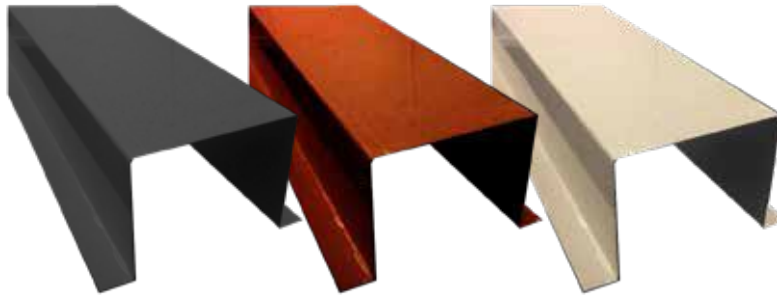

PART NO.	COLOUR	SIZE (mm)
CCAPBLK	Black	80 x 100 x 20
CCAPC	Classic Cream	80 x 100 x 20
CCAPDUNE	Dune	80 x 100 x 20
CCAPJASP	Jasper	80 x 100 x 20
CCAPR	Manor Red	80 x 100 x 20
CCAPMONU	Monument	80 x 100 x 20
CCAPB	Paperbark Beige	80 x 100 x 20
CCAPHG	Rivergum	80 x 100 x 20
CCAPSHGR	Shale Grey	80 x 100 x 20
CCAPW	Surf Mist White	80 x 100 x 20
CCAPG	Woodland Grey	80 x 100 x 20
CAP	Galvanised	80 x 100 x 20



PLASTIC CAPPING



90° FLAT ELBOW

PART NO.	SIZE (mm)
PE9080	80
PE90100	100



90° WALL BEND

- Off the wall

PART NO.	SIZE (mm)
PWB9080	80
PWB90100	100



WALL DUCT

- 2M lengths

PART NO.	SIZE (mm)
PD80	80
PD100	100



EAVE CAP

PART NO.	SIZE (mm)
PEC80	80
PEC100	100



VORTEX DUCT
FITTINGS
TRANSITIONS
ZONE MANAGEMENT
AIR DIFFUSERS AND GRILLES
EVAPORATIVE COOLING
VENTILATION
ELECTRICAL
COPPER

PLASTIC CAPPING

red-wall

FLEXIBLE JOINER

- 62cm lengths

PART NO.	SIZE (mm)
PFJ80	80
PFJ100	100



JOINER

PART NO.	SIZE (mm)
PJ80	80
PJ100	100



END CAP

PART NO.	SIZE (mm)
PWC80	80
PWC100	100



T JOINT

PART NO.	SIZE (mm)
PTJ100	100



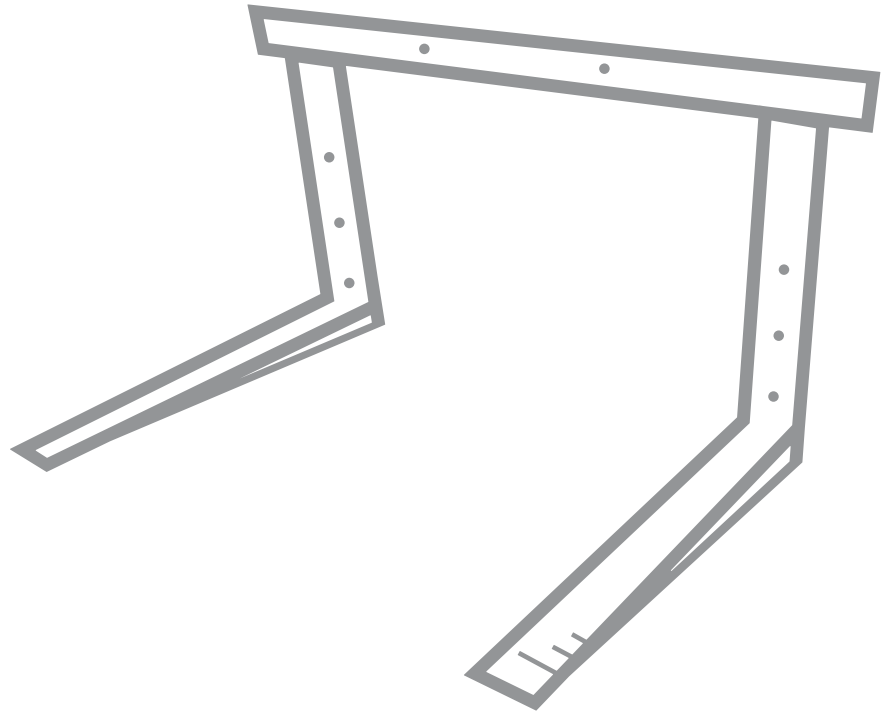

UNIT MOUNTING



BRACKETS & FEET

CONDENSER WALL BRACKET

- Galvanised Powder Coated

PART NO.	DIMENSIONS	LIMIT (kg)
CWB180	W: 450 H: 350 L:700	180
CWBX	W: 550 H: 450 L: 850	250



CONDENSER ROOF BRACKET

- Galvanised Powder Coated
- Pitch adjustable legs

PART NO.	DIMENSIONS	LIMIT (kg)
CRB150	W: 580 H: 580 L: 800	150



METAL CONDENSER FEET

- 1.2M lengths

PART NO.	DESCRIPTION	SIZE (mm)
TH25G	Galvanised	25 x 100
TH25Z	Zinc	25 x 100
TH50G	Galvanised	50 x 100
TH50Z	Zinc	50 x 100



PLASTIC CONDENSER FEET

- Set of 2
- 150Kg limit

PART NO.	DESCRIPTION	SIZE (mm)
FEET	PVC	450 x 95
FEET1MTR	PVC	1000 x 95



SUSPENSION

ISOLATION NEOPRENE MOUNTS



PART NO.	DIMENSIONS	SIZE (kg)
CM12	Mount Set of 4	30
NWM30R	Red - 45 x 88 x 37	15-30
NMAW20	White - 76 x 76 x 41	7-20
NMAR40	Red - 76 x 76 x 41	15-40
NMBR70	Red - 76 x 76 x 41	30-70
NMBB170	Blue - 76 x 76 x 50	80-170
NMBG100	Green - 76 x 76 x 50	50-100

ISOLATION SPRINGS

- Spring & 2x Rubber Cups



PART NO.	COLOUR	SIZE (kg)
IS30	Silver	15 - 30
IS45	Gold	22 - 45
IS70	Black	35 - 70
IS100	Green	50 - 100

SPRING HANGERS

- Spring & 1x Rubber Cup & 1x Metal Cup



PART NO.	COLOUR	SIZE (kg)
SH30	Silver	15 - 30
SH45	Gold	22 - 45
SH70	Black	35 - 70
SHB	HDG	140 x 70 x 65

WAFFLE PADS

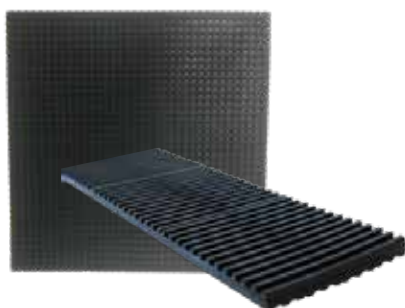

PART NO.	DESCRIPTION	SIZE (mm)
WP4545	Waffle Pad	450 x 450
WS1100	Waffle Strip	1000 x 100

OTHER PRODUCTS

SLABS



PART NO.	DESCRIPTION	SIZE (mm)
SLAB-M	HDPE UV MED	845 x 418 x 48
CON6045	Concrete - Light	600 x 450
EVC9045	Concrete - Light	900 x 450

CHIPBOARD



PART NO.	SIZE (mm)
CHIP18	1800 x 600

LINTEL & SLOTTED ANGLES



PART NO.	DESCRIPTION	SIZE (mm)
LINTEL	Lintel Bar	50 x 50 - 1.2M
SA30	Slotted Angle	30 x 30 x 2.5 - 3M
SA403M	Slotted Angle	40 x 40 x 2.5 - 3M
SA50	Slotted Angle	50 x 50 x 5 - 3M
SS40	Slotted Angle	40 x 40 - 3M

CONDENSER CAGES



PART NO.	DIMENSIONS W x D x H (mm)
CONCAGE1	1100 x 600 x 600
CONCAGE2	1100 x 600 x 800
CONCAGE3	1100 x 600 x 1200
CONCAGE4	1100 x 600 x 1600

- Secure Air Conditioning Equipment from Damage, Theft and Vermin
- Zinc Plated and Back Powder Coated Finish
- Side and Top Service Access Panels

*Please verify stock availability prior to order.

INSTALLATION HARDWARE



PART NO.	DESCRIPTION	PACK QTY
SLEEVE ANCHORS		
DB1050 SA1050	Sleeve Anchor - M10 - 10 x 50mm	25
DB1075 SA1077	Sleeve Anchor - M10 - 10 x 77mm	15
OTHER PRODUCTS		
DIA DIA2004	Drop In Anchor M10 x 30mm	50
DIA2007	Drop In Anchor M12 x 50mm	50
HC HC1040	Hex Coupler M10 - Zinc	25
GALSCREW GS1240	Galvanised Screw & Washer - 12g - 40mm	100
NA525 NA0525	Nylon Nail-In Anchor - 5.0 x 25mm	150
NA540 NA0540	Nylon Nail-In Anchor - 5.0 x 40mm	80
NA650 NA0650	Nylon Nail-In Anchor - 6.5 x 50mm	50
NA0675	Nylon Nail-In Anchor - 6.5 x 75mm	25
WALLMATE DWAN8	Nylon Dry Wall Anchor - 42mm (#8)	70
DWAS8	Zinc Alloy Dry Wall Anchor - 42mm (#8)	70



New part numbers arriving later 2019

INSTALLATION HARDWARE



PART NO.	DESCRIPTION	PACK QTY
NUTS, BOLTS & WASHERS		
M10B1030 HB1003	Hex Bolt & Nut M10 x 30mm - Zinc	50
FLNUTM10 HFN100	Hex Flange Nut M10 - Zinc	40
NUTM10 FNM100	Hex Nut M10 - Zinc	80
WASHER MW100	Mud Guard Washer M10 - Zinc	100
WASHM10 FW100	Flat Washer M10 - Zinc	150
RODM10 TR1003	Threaded Rod - 10mm - 3M	1

New part numbers arriving later 2019

HOOP IRON

PART NO.	DESCRIPTION	SIZE (mm)
HOPIRON	Galvanised	0.6 x 25mm - 30M

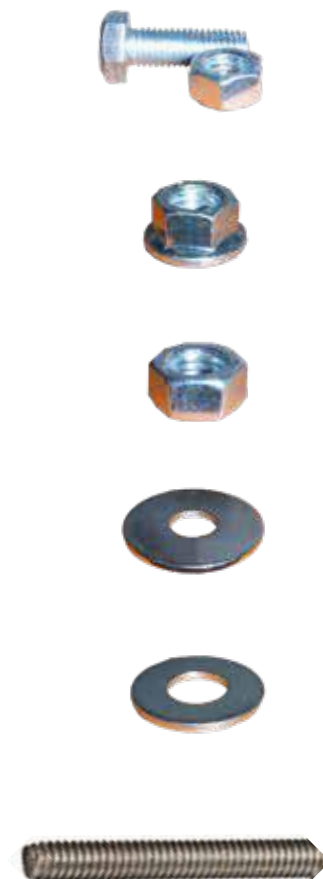

PIPE INSULATION

CAPPING

UNIT MOUNTING

DRAINAGE

PVC

TAPE AND STRAPS

FLUE

TOOLS

CELDEK PADS

INSTALLATION HARDWARE

PART NO.	DESCRIPTION
HANGERS & PLATES	
VHC	Vertical Hanger - Concrete M10 - 6.5 x 38mm
VHS	Vertical Hanger - Steel M10 - 25mm
VHT	Vertical Hanger - Timber M10 - 25mm
HHT	Horizontal Hanger - Timber M10 - 50mm
M10VHT50	Vertical Timber Hanger M10 - 50mm
CMP	Centre Mount Plate M10
VMP	Vertical Mount Plate M10
HMP	Horizontal Mount Plate M10
LDPH	Light Duty Purlin Hanger M10
HDPH	Medium Duty Purlin Hanger M10



VORTEX DUCT
FITTINGS
TRANSITIONS
ZONE MANAGEMENT
AIR DIFFUSERS AND GRILLES
EVAPORATIVE COOLING
VENTILATION
ELECTRICAL
COPPER

INSTALLATION HARDWARE

PART NO.	DESCRIPTION
----------	-------------

PCH	Purlin Clip
ZB	Z Bracket
UJC	Clear Uni J
M10BC	Beam Clamp M10 - Wide Mouth

REGISTER SPRINGS

URS	Register Spring - 10 x 35mm
URS1075	Register Spring - 10 x 75mm

PVC PIPE CLAMPS

M10PC20	PVC Pipe Clamp M10 - 20mm
M10PC25	PVC Pipe Clamp M10 - 25mm
M10PC32	PVC Pipe Clamp M10 - 32mm
M10PC40	PVC Pipe Clamp M10 - 40mm



PIPE INSULATION

CAPPING

UNIT MOUNTING

DRAINAGE

PVC

TAPE AND STRAPS

FLUE

TOOLS

CELDEK PADS

SEALANTS, SILICON & SPRAYS

SEALANTS

PART NO.	DESCRIPTION
SILCLEAR	Plumbers Translucent Clear 300g
SILDUCT	Duct Sealant 420g
SILFIRE	Firesound Grey 450g
SILGAP	Gap Filler 450g
SILGREY	Silicon Sealant Grey 400g
FMHPE	Fire Mastic Sealant Cart 310ml



SILICONE

PART NO.	DESCRIPTION
S184	Silicon Spray 330g



PAINT

- 250 grams

PART NO.	COLOUR
EX011	White Gloss
EX013	Black Matt
EX014	Black Gloss
EX019	Silver
EX043	Fluro Orange



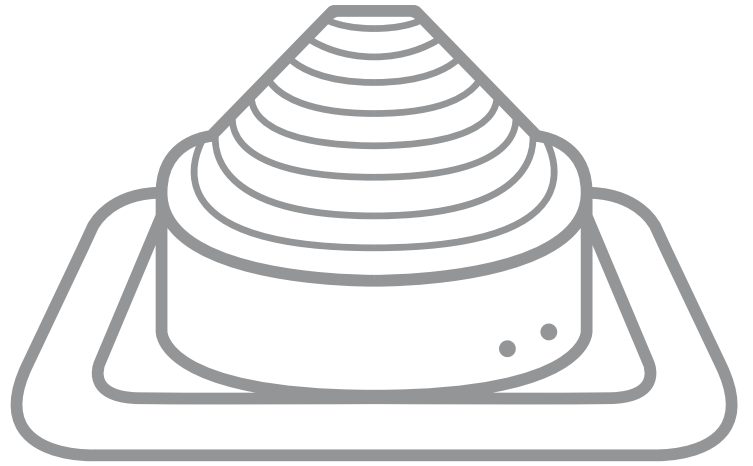

DRAINAGE



CONDENSATE PUMPS

MINIBLANC

Part No. - MINIBLANC

Performance

Max Flow	Max Head
12 Litres/hour	10M

Key Features

- Rotary diaphragm technology
- The small condensate pump that works and works
- Quietest in its class
- Self priming
- 3 year warrenty

Suitability

- Up to 16kW / 54,000Btu/h
- High wall split systems; Ducted units; Floor standing and Chassis units
- Perfect for smaller commercial and domestic units

 21 dB (A)



MINIORANGE

Part No. - MINIORANGE

Performance

Max Flow	Max Head	Max Suction Lift
12 Litres/hour	10M	5M

Key Features

- Submersible secondary reservoir included
- Plug and play
- Anti siphon device

Suitability

- Up to 16kW / 54,000Btu/h
- High wall split systems; Ducted units; Floor standing and Chassis units
- Perfect for smaller commercial and domestic units

 21 dB (A)



MAXIORANGE

Part No. - MAXIORANGE

Performance

Max Flow	Max Head	Max Suction Lift
35 Litres/hour	15M	2M

Key Features

- Submersible secondary reservoir included
- High power motor
- Superior performance

Suitability

- Up to 46kW / 157,000Btu/h
- High wall split systems; Ducted units; Floor standing and Chassis units
- Perfect for smaller commercial and domestic units

 19 dB (A)



CONDENSATE PUMPS

MICRO-V

Part No. - MICROV

Performance

Max Flow	Max Head	Max Suction Lift
14.5 Litres/hour	10M	2M

Key Features

- Soft start
- Plug and play
- 3 year warranty

Suitability

- Up to 19.3kW / 66,000Btu/h
- High wall split systems; Ducted units; Floor standing and Chassis units
- Perfect for smaller commercial and domestic units

 19 dB (A)



MINILIME

Part No. - MINILIME

Performance

Max Flow	Max Head
12 Litres/hour	10M

Key Features

- Acoustic damper
- Pump sits in trunking elbow
- Left or right install
- Self priming

Suitability

- Up to 16kW / 54,000Btu/h
- High wall split systems
- Perfect for commercial use where silence is important

 20 dB (A)



MAX HIGH FLOW TANK PUMP

Part No. - FP3349

Performance

Max Flow	Tank Capacity
550 Litres/hour	1.7L

Key Features

- IP24 Splash Proof
- Easy tank access
- Built in spirit level
- Plug and play

Suitability

- Up to 733kW / 2.5M Btu/h
- Ducted units; Floor standing, Chassis units and Cassettes

 44 dB (A)



OTHER PRODUCTS

FLEXIBLE DRAIN HOSE

- Black lining
- Suitable for both 14/16mm pipe

PART NO.	DESCRIPTION	SIZE (mm)
FDH16	Corrugated	16 - 50M



P TRAP

- 3/4 Standard Trap
- 3/4 Cross
- 3/4 Tee
- 3x Red Caps
- Yellow Cleaning Label

PART NO.	DESCRIPTION	SIZE (mm)
PTRAP	Condensate Trap	20



CLEAR TUBING

PART NO.	DESCRIPTION	SIZE (mm)
6MMTUBE	Clear Tube	6 x 9 - 30M



DRIP TRAYS

- 55mm Fold
- Galvanised

PART NO.	SIZE (mm)
DT8383	830 x 830
DT1183	1100 x 830
DT1275	1250 x 750
DT1483	1400 x 830
DT1595	1500 x 950
DT1783	1700 x 830



PART NO.	DESCRIPTION	SIZE (mm)
F0BS	45° Multi Vent - 0-35mm - Solar	100 x 100
F1B	45° - 5-55mm - Black	139 x 139
F1BS	45° Multi Vent - 5-55mm - Solar	139 x 139
F2B	45° - 5-76mm	178 x 178
F3B	45° - 5-127mm	221 x 221
F4B	45° - 75-175mm	280 x 280
F7B	45° - 150-300mm	456 x 456
DRF101GB	Rapid Flash - Lead Free Fully Adhesive Base Flashing - 5-127mm Tile / Metal Roofs	370 x 560



BAL - Bushfire Attack Level

- Black Silicon - Rating 12.5
- Red Silicon - Rating 29.0 Not stocked but available upon request

THE ELEPHANT

ROOF SEAL KIT

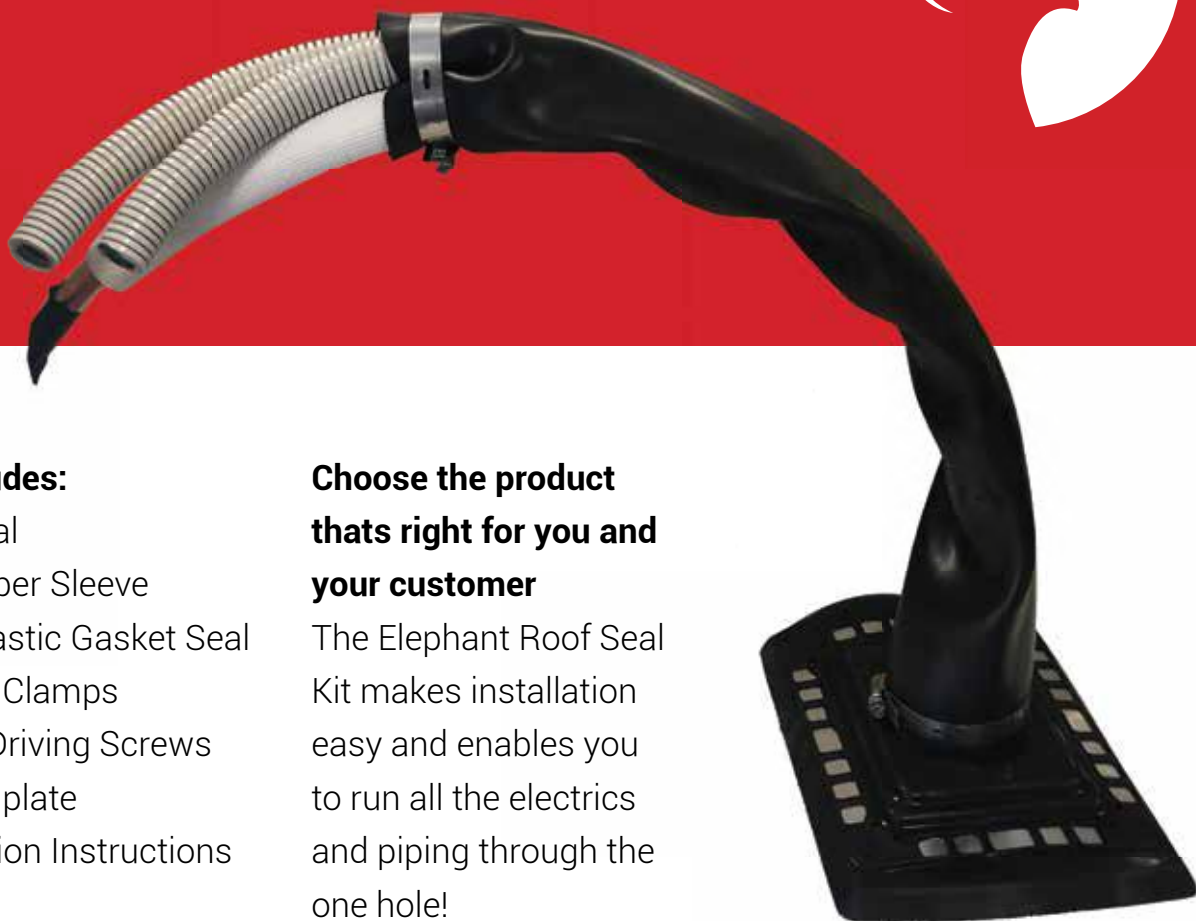

Kit Includes:

Boot Seal
 1M Rubber Sleeve
 Butyl Mastic Gasket Seal
 2x Tube Clamps
 4x Self Driving Screws
 Cut Template
 Installation Instructions

Choose the product thats right for you and your customer

The Elephant Roof Seal Kit makes installation easy and enables you to run all the electrics and piping through the one hole!

Why choose Elephant?

Easy to install
 Eliminates the use of
 multiple dektites
 Top quality materials
 Epdm rubber
 Weather/Water proof
 High temperature range
 BAL approved
 VBA approved
 UV resistant

The ultimate all in 1 kit!



- No more water leaks
- No more silicon use

PART NO.	DESCRIPTION
ELEPHANT	Elephant Roof Seal Kit



PVC



PVC PIPE & JOINERS

PVC PIPE



PART NO.	SIZE (mm)
PVC15	15 - 3.9M
PVC20	20 - 3.9M
PVC25	25 - 3.9M
PVC40	40 - 4M

45° EQUAL ELBOW

PART NO.	BAG QTY	SIZE (mm)
PVC45E15	5	15
PVC45E20	5	20
PVC45E25	5	25
PVC45E40	5	40



90° EQUAL ELBOW

PART NO.	BAG QTY	SIZE (mm)
PVC90E15	5	15
PVC90E20	5	20
PVC90E25	5	25
PVC90E40	5	40



EQUAL TEE

PART NO.	BAG QTY	SIZE (mm)
PVCT15	5	15
PVCT20	5	20
PVCT25	5	25



SOCKETS

DOUBLE END SOCKET

PART NO.	BAG QTY	SIZE (mm)
PVCS15	5	15
PVCS20	5	20
PVCS25	5	25



MALE VALVE SOCKET

PART NO.	BAG QTY	SIZE (mm)
PVCM15	5	15
PVCM20	5	20
PVCM25	5	25



DRAIN PAN ADAPTOR

PART NO.	BAG QTY	SIZE (mm)
PVCDPF15	5	15



FEMALE FAUCET SOCKET

PART NO.	BAG QTY	SIZE (mm)
PVCFI25	5	25



OTHER PRODUCTS

REDUCING BUSH

PART NO.	BAG QTY	SIZE (mm)
PVCBUSH2520	5	25 - 20



REDUCING SOCKET

PART NO.	BAG QTY	SIZE (mm)
PVCR2015	5	20 - 15
PVCR2520	5	25 - 20



SADDLE CLIPS

PART NO.	BAG QTY	SIZE (mm)
PVCCLIP15	100	15
PVCCLIP20	100	20
PVCCLIP25	100	25



PVC GLUE

- AS/NZS 3879, AS/NZS 4020 Approved

PART NO.	COLOUR	SIZE (ml)
PVCGB	Blue	500
PVCGC	Clear	500



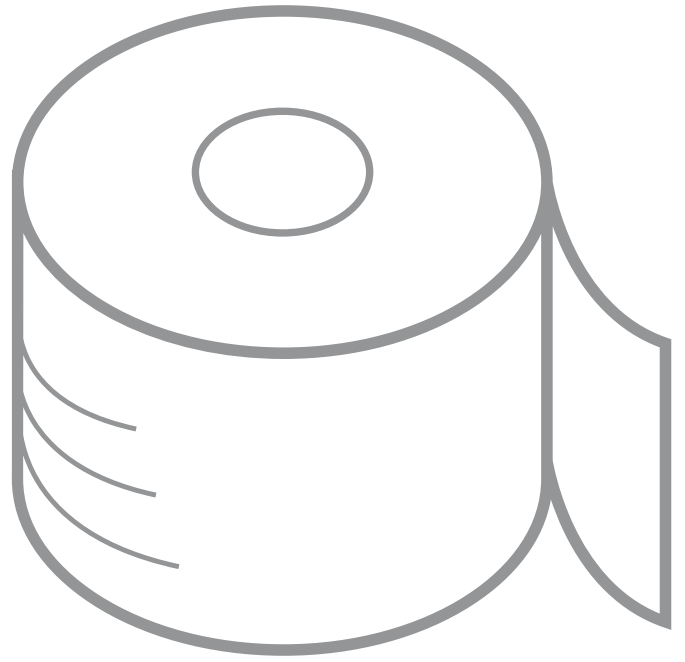

TAPES & STRAPS



TAPES

PART NO.	DESCRIPTION	SIZE (mm)
----------	-------------	-----------

DUCT TAPE		
------------------	--	--

DTAPE	Duct Tape - Grey	48 - 30M
-------	------------------	----------

BTAPE	Duct Tape - Black	48 - 30M
-------	-------------------	----------

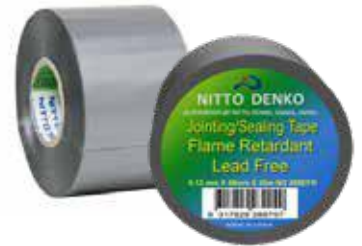

FOAM TAPE		
------------------	--	--

FT15	Foam Tape - PE	8 - 20M
------	----------------	---------



ALUMINIUM TAPE		
-----------------------	--	--

FT50	Aluminium Tape - Plain	48 - 50M
------	------------------------	----------

FTR50	Aluminium Tape - Reinforced	48 - 30M
-------	-----------------------------	----------

FTR75	Joining Tape RF - Foil	75 - 50M
-------	------------------------	----------



ELECTRICAL TAPE		
------------------------	--	--

ETAPE	Plain Earth	19 - 20M
-------	-------------	----------



HANGING TAPE		
---------------------	--	--

HTAPE	Hanging Tape - Blue	25 - 50M
-------	---------------------	----------

HS75	Hanging Strap - Blue	75 - 50M
------	----------------------	----------

DUCSAD	Duct Saddle	75 - 10M
--------	-------------	----------

SHS75	Sisalation Hang Strap	75
-------	-----------------------	----



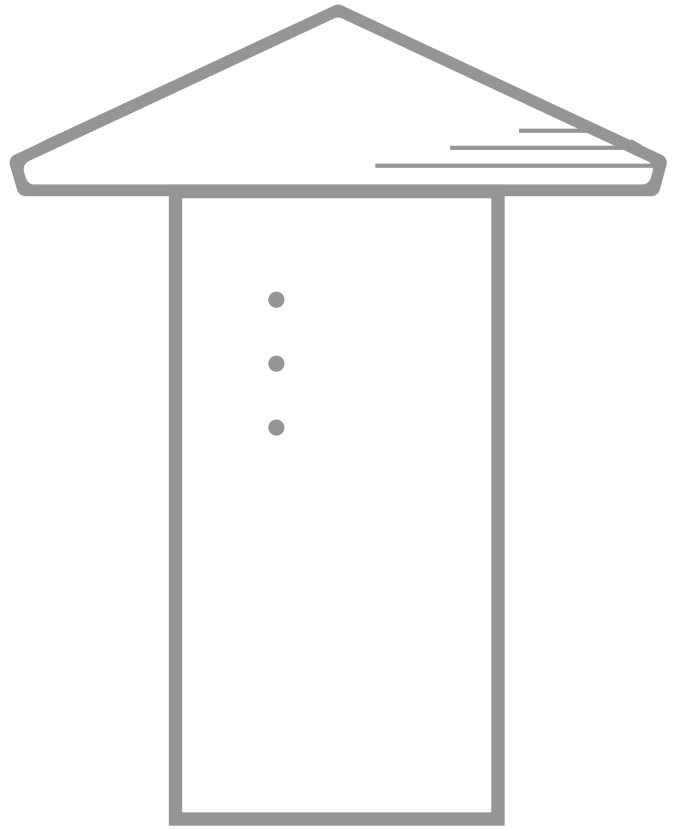

FLUE

COWLS & BENDS - GAS

COWLS

PART NO.	SIZE (mm)
COW100	100
COW125	125



FLUES

PART NO.	SIZE (mm)
FLU100	100
FLU125	125



45° BENDS

PART NO.	SIZE (mm)
BEN45100	100
BEN45125	125



90° BENDS

PART NO.	SIZE (mm)
BEN90100	100
BEN90125	125



COWLS & BENDS - GAS

FLUE CLIPS

PART NO.	SIZE (mm)
CLI100	150
CLI125	200



BOLTED SLEEVES

PART NO.	SIZE (mm)
BSL100	100
BSL125	125



GALVANISED ROOF COWLS - CHINAMANS HAT

PART NO.	SIZE (mm)
COW150	150
COW200	200



TOOLS

HVAC TOOLS

DV SERIES VAC PUMPS

- Suitable for R32 gas
- Gas ballast valve
- 2 stage direct drive to achieve deep
- 1/4", 3/8" & 5/16" Access tee with brass caps
- 240V/50Hz - 5 meter lead
- Ergonomic handle and shock-proof base

Performance	DV50ER32	DV100ER32
Voltage	240V/50Hz	240V/50Hz
Air Displacement	50 l/m	100 l/m
Ultimate Vacuum	25 microns	25 microns
Power	190W	360W
RPM	1440	1440
Oil Capacity	300ml	450ml



PART NO.	DESCRIPTION
DV50ER32	
DV100ER32	

DIGITAL VACUUM GAUGE

- Vacuum Reading Range - 100,000 to 10 microns
- Working Temperature - +0°C to 48.9°C
- Improved response time for instantaneous vacuum reading
- Allows for direct connection to the AC unit without a hose
- Audible and visual alarms when target vacuum level is achieved
- Measures in microns, PSIA, inHg, Pascals, Torr, mTorr & mBar



PART NO.	DESCRIPTION
DV24N	Manifold Gauge Set 5/16 Hoses R410a & R32

MANIFOLD GAUGE SET



- Suitable for R410A gas
- 5 feet charging hose
- 5/16" for Red and Blue, 1/4" SAE for yellow
- Working pressure 800/ Bursting pressure 4000 psi

PART NO.	DESCRIPTION
BD21465	Manifold Gauge Set 5/16 Hoses R410a & R32
BD23433	Hose Set 36" - 1/4" - 5/16"
BD23435	Hose Set 60" - 1/4" - 5/16"



HVAC TOOLS

MULTI SIZE TUBE BENDER

- Mandrel Sizes: 1/4", 5/16", 3/8", 1/2", 5/8", 3/4", 7/8"
- Tube Bender set comes in different sizes of Aluminium Bending Forms, and it is easy to assemble.
- Aluminium bending formers make it easy to remove the bent tubes without damaging the tool or the bent tubes.
- The reverse adapters enable the set to perform downward and upward bending.



PART NO.	DESCRIPTION
12999	Adjustable from 1/4" - 7/8"

QUICK ACTION TUBE BENDERS

PART NO.	SIZE (inch)
BD12106	3/8"
BD12108	1/2"
BD12110	5/8"
BD12112	3/4"



RATCHET WRENCH

PART NO.	SIZE (inch)
T21127U	1/4" - 3/16" x 3/8" - 5/16"



CORE REMOVER WITH PORT

PART NO.	SIZE (inch)
A32525N	1/4"
A32530N	5-16"



HVAC TOOLS

FLARING TOOL



- Lightweight strong aluminium - Titanium finish
- Quick and easy to use
- Comes complete with pipe locator to guarantee consistent flares



PART NO.	DESCRIPTION
BD14545	1/4" - 3/4" Eccentric Cone Flaring Tool

TUBE CUTTERS



- Spring loaded
- Good size for most working conditions
- Easy to grip
- Smooth to turn
- Titanium coated cutter wheels
- Supplied with spare cutter wheel



PART NO.	DESCRIPTION
BD11166	1/8" - 7/8" Small Tube Cutter
BD11288	1/8" - 1 1/4" Medium Tube Cutter
BD11382	1/8" - 1 5/8" Medium Tube Cutter



BENDING SPRINGS

PART NO.	DESCRIPTION
BS6	3/8" - 10" Length
BS8	1/2" - 10" Length
BS10	5/8" - 10" Length
BS12	3/4" - 10" Length



ADAPTOR

PART NO.	DESCRIPTION
A31665	Male Adaptor 1/4 Female x 5/16 Male R410a



HVAC TOOLS

MAPP GAS & TORCH

PART NO.	DESCRIPTION
MAPP	400g Gas Bottle
PTV450	Piezo Torch



SILVER SOLDER

PART NO.	DESCRIPTION
SILSOLDER	Silver



REAMER

PART NO.	DESCRIPTION
RT21655	Deburring Tool
RT21660	Deburring Tool (blade non-replaceable)
RT11006	Copper and stainless steel internal/external reamer 1/4" - 1 1/2" OD



HVAC CLEANERS

PART NO.	DESCRIPTION
412775	Black Hawk Foam Coil Cleaner
416675	Evap Fresh No Rinse



VORTEX DUCT
FITTINGS
TRANSITIONS
ZONE MANAGEMENT
AIR DIFFUSERS AND GRILLES
EVAPORATIVE COOLING
VENTILATION
ELECTRICAL
COPPER

HVAC CONSUMABLES

VACCUUM OIL

PART NO.	DESCRIPTION
DV012	JB Black Gold Vac Pump Oil 946ml



MICRO LEAK DETECTOR

PART NO.	DESCRIPTION
418224	Cal Blue - 1 Litre



BRUSH ON LEAK DETECTOR

PART NO.	DESCRIPTION
RT175B	Brush on Blue - 230ml



NYLOG SEALANT LUBE

PART NO.	DESCRIPTION
RT201B	Gasket Thread Sealant and Assembly Lube - 30ml



PIPE INSULATION

CAPPING

UNIT MOUNTING

DRAINAGE

PVC

TAPES AND STRAPS

FLUE

TOOLS

CELDEK PADS

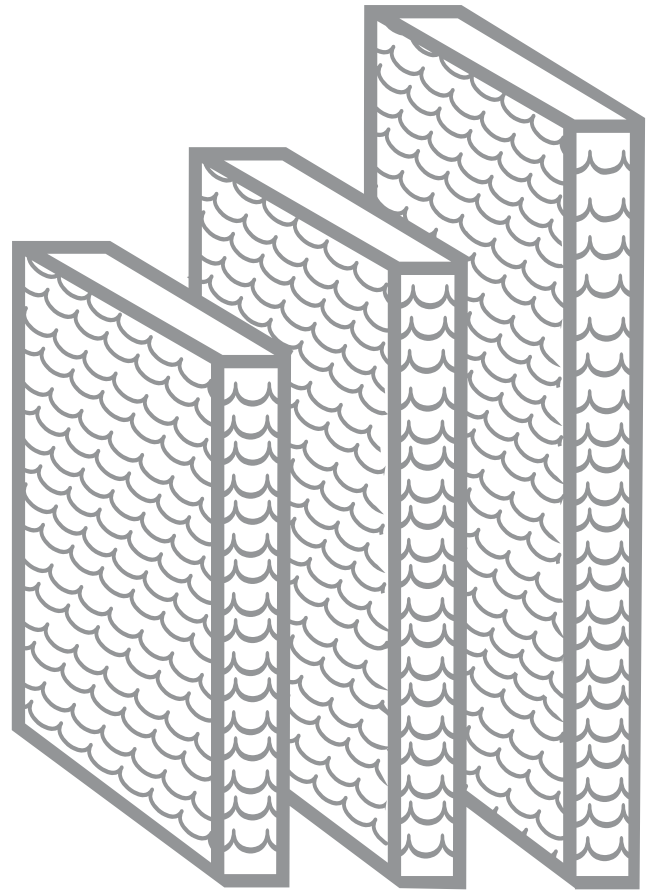

CELDEK PADS



CELDEK PADS - TO SUIT

HVAC CLEANERS

- Subject to availability
- Price upon application

BRANDS

Anotron & Coolair

Braemar

Brivis

Bonaire & Climate

Carrier

Celair & Climate

Coolbreeze & Air Group

Omega

Seeley International & Breezaire

Stadt - Aqua Breeze



APPLICATION FOR COMMERCIAL CREDIT ACCOUNT

To: AUSTRALIAN AIRCONDITIONING DISTRIBUTORS PTY LTD ACN 139 947 363 and each of its subsidiaries, divisions, affiliates, associated companies and related entities and any successors and assigns (AAD).

1. CUSTOMER:

Name / Company Name:		ACN:
		ABN:
Business / Trading Name:		Email:
Ph: ()	Fax: ()	Mobile:

DIRECTORS OR INDIVIDUAL SOLE TRADER:

Name:		
Name:		
Residential Address:		
Ph: ()	Fax: ()	Mobile:

2. APPLICATION: The Customer applies for a credit account and agrees that the Terms and Conditions of Trade (attached) will govern all dealings the customer has with AAD. These terms are also available on AAD's website: www.aad.net.au

3. CREDIT LIMIT REQUESTED:

\$

4. EXPECTED MONTHLY PURCHASES:

\$

5. ACCOUNTS PAYABLE CONTACT:

Name:	Email:
Ph: ()	Fax: ()

6. TRADING DETAILS:

Business Address:	
Address for correspondence:	
Website Address:	Date Business Commenced:
Type of Business:	How Long Current Owner? Since:
Names of Customer's Related / Subsidiary Companies / Partnerships:	
Is the Customer's Business Premises leased: Yes <input type="checkbox"/> No <input type="checkbox"/>	If premises are leased, provide name, address of Landlord and Landlord's agent:

7. PARTNER / SOLE TRADER / DIRECTOR DETAILS:

	Names of directors (if a company), partners / sole trader (if partnership or sole trader)	Residential Address	Date of Birth	Private Telephone
1.				
2.				
3.				
4.				

8. TRUSTS:

Is the Customer involved or associated in any way with a Trust (e.G: Family Trust or Unit Trust)?

Yes No

9. INSOLVENCY:

Has the Customer or any of its directors or partners been insolvent or involved in any way with an insolvent (liquidation, receiver, Administrator, bankruptcy or Part X, etc)?

Yes No

10. FRANCHISES:

Is the Customer involved or associated in any way with any Franchise, whether as Franchisor, Franchisee, Licensee or otherwise?

Yes No

11. FINANCIAL DETAILS:

Bank:	Branch:	Phone No:
-------	---------	-----------

12. TRADE REFERENCES:

	Name	Address	Telephone	Facsimile
1.			()	()
2.			()	()
3.			()	()

13. MEANS AND ABILITY TO PAY: The Customer warrants that it is solvent and has the future ability to pay all of its debts as when they fall due.

14. ACCEPTANCE: AAD will be deemed to have accepted this Application if it allows the Customer to trade with it on credit with any division or part of AAD. The Customer agrees that AAD may refuse to trade with it on credit for any reason whatsoever or withdraw the credit accommodation at any time.

15. OTHER DIVISIONS: The Customer agrees that this Application relates to all dealings with AAD and any part or member of the AAD group.

16. PURPOSE: The Customer declares and warrants that any credit will be used wholly or predominantly for commercial, business and/or investment purposes (or both) and not for the Customer's personal, domestic or household purposes.

IMPORTANT: Personal Customers: You should not sign this application (which includes the declarations and warranties in this part 16 unless credit is wholly or predominantly for business or investment purposes. No credit shall be provided to Personal Consumers.

17. INACTIVE ACCOUNTS: If a Customer has not used a credit facility for 12 months, a new application for Commercial Credit Account may be required to be completed and submitted, but this will be in addition to (and will not derogate from nor affect) any obligation of the Customer or any Guarantor which arose under any preceding Application for Commercial Credit Account.

18. CREDIT INFORMATION and PRIVACY ACT 1988 (CTH): The Customer and the Agent irrevocably authorise AAD, its servants and agents to make such enquiries as they deem necessary to investigate the credit worthiness of the Customer, its directors and the Agent from time to time, including the making of the enquiries with persons nominated as trade references, the bankers of the Customer any credit provider or Credit Reporting Agency and including personal credit and consumer credit information and Land Data/property inquires and name searches (hereinafter called "the Sources"). The Customer and the Agent hereby authorise the Sources to disclose to AAD such information concerning the Customer and the Agent which is within their possession. The Customer and the Agent agree that the information provided on this Credit Application concerning the Customer and the Agent and any relevant trading information arising from any dealings between the Customer and AAD may be disclosed to a Credit Report Agency or any other interested person, subject to AAD's Privacy Policy and can be obtained from the company secretary, AAD at 57-63 McNaughton Road Clayton Victoria 3168. The Customer authorises AAD to retain any information discovered under this clause. The customer acknowledges that AAD may be required to disclose the credit information to third Parties and hereby consents for AAD to do so.

19. PERSONAL PROPERTIES AND SECURITIES ACT 2009 (CTH)(PPSA): The customer acknowledges that this application for credit constitutes an act giving rise to a Security Agreement within the meaning of the PPSA and causes the Customer to grant to AAD Security Interests.

20. GUARANTEE: (a) In consideration for the supply of the Goods to the Customer and at the request of AAD, the Customer agreed to appoint: (i) where a company, the Customer's duly appointed directors, whether past, present or future; or (ii) where an individual sole trader, the Customer acting in his personal capacity, as Guarantor/s.

(b) Each Guarantor, and where more than one, jointly and severally, unconditionally and irrevocably guarantees: (i) the punctual payment of all Amounts Payable (including interest and damages) by the Customer to AAD, in connection with the supply of Goods to the Customer or any transaction contemplated by this Application for Commercial Credit and the Terms and Conditions, whether present or future, actual or contingent or incurred alone, jointly and/or severally, and without regard to the capacity in which the Customer is liable ("Guaranteed Moneys"); and (ii) the due observance and performance by the Customer of all its duties and obligations contained or implied in this Application for Commercial Credit and the Terms and Conditions ("Guaranteed Obligations").

(c) In the event the Customer fails to make due and punctual payment or performance of the Guaranteed Moneys or Guaranteed Obligations (respectively), AAD may demand (in writing) that the Guarantor carries out the relevant obligation in lieu of the Customer. The Guarantor must comply with such written demand immediately, failing which AAD may enforce its rights and remedies, personally against the Guarantor, regardless of whether it may have recourse against the Customer or whether HVAC elects to take action against the Customer.

(d) Without prejudice to any other rights or remedies available to AAD, the Guarantor grants security for its duties and obligations under this clause 21 by way of charge pursuant to clause 22.

(e) In undersigning this document, the Guarantor acknowledges that: (i) AAD is providing supply to the Customer in reliance on this guarantee; (ii) the Guarantor expects to derive a direct or indirect commercial benefit from providing this guarantee; (iii) it has sought, or had the opportunity to seek, independent legal advice with respect to the nature and extent of its duties and obligations as Guarantor under this Application for Commercial Credit and the Terms and Conditions; and (iv) it provides this guarantee free from any influence, duress or undue pressure from any other third parties.

The guarantee contained under this clause 21 is continuing and will survive any rightful termination of the Application for Commercial Credit Account, the Terms and Conditions or associated Contract.

21. SECURITY: (a) The Customer and Guarantor/s acknowledge that Application for Commercial Credit Account and the Terms and Conditions constitute a security agreements and that AAD may register a financing statement in respect of the security interests provided herein.

(b) Without prejudice to any other provision contained herein, the Customer and the Guarantor grants by way of charge in favour of AAD all of its interest in the Customer's and Guarantor's present and after-acquired real property to secure the performance of the Customer's obligations under the Contract, including payment of the Amount Payable.

(c) The Customer and/or Guarantor acknowledges that AAD have: (i) a caveatable interest in any real property of the Guarantor and hereby provides its consent for AAD to lodge a caveat over that property. Upon demand by AAD, the Guarantor agrees to immediately execute a mortgage on terms satisfactory to AAD to more particularly describe the security interest conferred by this clause; (ii) a registrable security interest (as defined under the Personal Property Securities Act 2009 (Cth)) in all present and after-acquired personal property of the Guarantor and hereby consents for AAD to register a security interest over that property.

(d) Upon demand, the Customer and/or Guarantor agrees to immediately execute a mortgage on terms satisfactory to AAD to more particularly describe the security interest conferred by this clause 22. Should the Customer and/or Guarantor fail within a reasonable time of such demand to execute that mortgage, then the Customer and/or Guarantor irrevocably appoints AAD as its attorney with authority to do on its behalf anything that it may lawfully authorise an attorney to do including, without limitation, to make, sign, execute, seal and deliver any document and to take possession of, use, sell or otherwise dispose of any real property of the Customer and/or Guarantor, to the extent of the Amount Payable.

22. CUSTOMER:

If a corporation, at least two (2) of the current directors must sign.

If an individual/sole trader, the principal must sign and have his/her signature witnessed by an independent adult witness.

* Cross out whichever description does not apply

Dated: / /20	Dated: / /20
Signature: <i>(Director and Secretary* / Principal*)</i>	Signature: <i>(Director* / Witness*)</i>
Full Name:	Full Name:
Usual Address:	Usual Address:
Contact No.	Contact No.
<p>The Customer HEREBY REPRESENTS and WARRANTS that the information set out in this application is true and correct, it has read the information, including the Terms and Conditions and understands its duties and obligations and signs this application form free from any influence or undue pressure or duress. The Customer has sought or been provided the opportunity to seek independent legal advice as to the extent and nature of its duties and obligations and ACKNOWLEDGES that AAD will rely upon such representations and warranties to grant credit and/or to deal with the Customer.</p>	

23. GUARANTORS:

Dated: / /20	Dated: / /20
Signature: <i>(Director and Secretary* / Principal*)</i>	Signature: <i>(Director* / Witness*)</i>
Full Name:	Full Name:
Usual Address:	Usual Address:
Contact No.	Contact No.
<p>The Guarantor HEREBY REPRESENTS and WARRANTS that the information set out in this Application is true and correct, it has read the information contained in this Application for Commercial Credit (and specifically clauses 18-21) and including the Terms and Conditions and understands its duties and obligations and signs this application form free from any influence or undue pressure or duress. The Guarantor has sought or been provided the opportunity to seek independent legal advice as to the extent and nature of its duties and obligations and ACKNOWLEDGES that AAD will rely upon such representations and warranties as set out in this Application for Commercial Credit and the Terms and Conditions.</p>	

In this document:

- (a) "Amount Payable" means, at any time, all amounts payable by the Customer to AAD at that time (whether or not those amounts have become due for payment under this Application for Commercial Credit and the Terms and Conditions) in connection with the Goods or the Contract (including, without limitation, any invoiced amount, interest, indemnity sums, costs or expenses);
- (b) "Contract" means the Terms and Conditions and, for an Order, the relevant Order Acknowledgment;
- (c) "Customer" means the customer specified in this Application for Commercial Credit;
- (d) "Guarantor" means persons named as Guarantor under the Application for Commercial Credit;
- (e) "PPSA" means Personal Property Securities Act 2009 (Cth);
- (f) the terms "financing statement", "proceeds", "purchase money security interest", "security agreement", "security interest" and "verification statement" have the respective meanings given to them under, or in the context of, the PPSA;
- (g) unless otherwise stated, an expression used or defined in the Corporations Act 2001 (Cth) has the same meaning in the Application for Commercial Credit and the Terms and Conditions;
- (h) words indicating the singular include the plural and vice versa.

TERMS & CONDITIONS OF SALE

To the fullest extent legally possible, all dealings between AUSTRALIAN AIRCONDITIONING DISTRIBUTORS PTY LTD ACN 139 947 363 (and each of its subsidiaries, divisions, affiliates, associates and related body corporates) ("AAD") and any Customers relating to any Goods or services are subject to the following Terms and Conditions unless otherwise agreed in writing:

In this document:

- (a) "Amount Payable" means, at any time, all amounts payable by the Customer to AAD at that time (whether or not those amounts have become due for payment under the Terms and Conditions) in connection with the Goods or the Contract (Including, without limitation, any invoiced amount, interest, indemnity sums, costs or expenses);
- (b) "Contract" means the Terms and Conditions and, for an Order, the relevant Order Acknowledgment;
- (c) "Customer" means the customer specified in an application for commercial credit (or if there is no application, the person placing the Order, or on whose behalf the Order is placed, with AAD);
- (d) "Guarantor" means persons named as Guarantor under the application for commercial credit;
- (e) "PPSA" means Personal Property Securities Act 2009 (Cth);
- (f) The terms "financing statement", "proceeds", "purchase money security interest", "security agreement", "security interest" and "verification statement" have the respective meanings given to them under, or in the context of, the PPSA;
- (g) Unless otherwise stated, an expression used or defined in the Corporations Act 2001 (Cth) has the same meaning in the Terms and Conditions;
- (h) Words indicating the singular include the plural and vice versa.

1. Orders, Acceptance and Terms and Condition

- (a) An order or an offer to purchase of Goods must be made by the Customer in writing ("Order") and will be deemed accepted when the Customer receives an acknowledgement of the Order from AAD or the delivery of the relevant Goods, whichever first occurs ("Order Acknowledgement"). In submitting an Order to AAD constitutes deemed acceptance of these Terms and Conditions by the Customer.
- (b) In submitting the Order, the Customer hereby represents and warrants that it is (and will continue to be at all times while the Terms and Conditions are applicable) solvent and able to pay all of its debts as and when they fall due and payable.
- (c) AAD may in its absolute discretion request that a deposit is paid as part payment of the Order on such terms and in such amounts as it deems reasonable.
- (d) The Terms and Conditions shall continue to apply unless otherwise agreed in writing or unless the commercial relationship between the parties is validly terminated indefinitely.
- (e) The Customer must supply full and complete technical specifications, drawings, designs and any other information relevant to their purchase, in conjunction with the Order. The Customer acknowledges that AAD may rely on such information in supplying the Customer the Goods and will further indemnify AAD in respect of its reliance on such information.
- (f) In the event an Order is cancelled by the Customer, the Customer must pay all reasonable costs Incurred by AAD in processing the Order prior to cancellation.

2. Quotations

- (a) All Quotations must be made to the Customer in writing and will expire in 28 days from the date of the Quotation. Quotations will not be construed as an obligation to sell but merely an invitation to treat and no contractual relationship will arise until there is an Order Acknowledgement of the Customer's Order.
- (b) AAD is at liberty to amend, vary or withdraw a Quotation by written notice to the Customer, regardless of whether an Order has already been placed, at any time and for any reason it sees fit Including where AAD believes that there has been material changes in the Customer's business or circumstances under which the Quotation was first offered.
- (c) To secure a Quotation pending placement of an Order, the Customer may be required to pay a deposit and any reasonable costs Incurred by AAD in holding the Goods with respect to the Quotation. However, payment of the deposit is not deemed acceptance of the Quotation.
- (d) Unless otherwise made known to the public, all Quotations are strictly confidential and the Customer must not disclose the details of the Quotations to a third party, without prior written consent from AAD.

3. Purchase Price

- (a) Unless where a Quotation has been accepted providing a specified purchase price, the purchase price for Goods supplied and charge rate for services rendered will be at AAD's list price ruling as at the nominated date of delivery.
- (b) All prices are expressed net of any applicable goods and services tax, value added tax, freight charges and customs duty that shall be added to the amount to be paid by the Customer unless otherwise agreed.
- (c) Prices are subject to change without notice and are not binding on AAD. Upon alteration of the price, the Customer may cancel any Order (or part thereof) at the new price within 5 days of AAD providing notice of the change of price.

4. Payment

- (a) For so long as AAD has agreed to provide credit to the Customer under the Terms and Conditions and provided that such credit has not been otherwise withdrawn, refused or suspended, payment for the Goods must be made in full (without any set-off, deduction or reduction) and be received by AAD within 30 calendar days from the date of the Sales Invoice.
- (b) Where any part of the Sales Invoice is in dispute, the balance will remain payable and must be paid when due.
- (c) Upon payment AAD may apply such payment to any Amounts Payable in such a manner or priority as AAD deems reasonable and further AAD reserves its right to set off any amount due and payable by AAD to the Customer against any amount due and payable by the Customer to AAD.
- (d) Any failure to make due and punctual payment of the Sales Invoice will be deemed a material default and which entitles AAD to terminate any Contract or suspend any further supply of deliveries.

5. Interest

Interest is payable on any Amount Payable not paid on or before the due date at a rate of 3% p.a. above the rate prescribed under the Penalty Interest Rates Act 1983 (Vic), calculated daily and payable on demand, plus an additional monthly administration fee of \$25 per month.

6. Credit

- (a) Any agreement by AAD to grant the Customer credit upon the Terms and Conditions has been or will be made on the basis of a credit application and such other documents and information as may be required by AAD and are provided to its reasonable satisfaction.
- (b) If AAD exercises its powers to withdraw, refuse or suspend credit under clauses 6(c) or 14(b) or otherwise under the Terms and Conditions, AAD will only supply Goods to the Customer on the basis of cash in advance.
- (c) The granting of credit does not oblige AAD to extend any particular amount of credit to the Customer and AAD may withdraw, refuse, suspend or limit credit to the Customer at any time, in its absolute discretion, without notice or providing any reason.
- (d) The Customer must notify AAD in writing if there is any change in the shareholding or ownership of the Customer or any material change in the Customer's financial position.

7. Delivery

- (a) If requested by the Customer, and agreed by AAD, AAD will arrange delivery of the Goods to an address specified by the Customer, at the Customer's sole cost and expense.
- (b) In such cases, the Customer (or a representative of the Customer) must be present at the agreed place and time for delivery and must sign the delivery docket as acknowledgement that the Goods (and the quantities so described therein) have been delivered and comply with the Order.
- (c) AAD's responsibility for delivery shall cease at the delivery address at which point the risk in the Goods will pass to the Customer. Either a certificate purporting delivery was effected signed by a representative of AAD or a signed delivery docket (or both) will be deemed conclusive evidence of delivery.
- (d) If a Customer arranges for its own delivery, the risk will pass when the Goods are loaded onto the Customer's nominated delivery vehicle and the Customer acknowledges that it will be solely responsible to arrange insurance in respect of the Goods.
- (e) AAD shall not be liable for:
 - (i) any failure to deliver or delay in delivery for any reason; or
 - (ii) any damage or loss due to unloading or unpacking; or
 - (iii) damage or injury to person or property caused upon entering premises to deliver the Goods. Any costs Incurred by AAD due to a failure by the Customer to accept the Goods at the time of delivery will be reimbursed by the Customer to AAD.
- (f) AAD may deliver in instalments where all such instalments will be separately invoiced and must be paid without regard to the delivery of the subsequent instalments. A partial delivery of an Order will not invalidate the balance of the Order.
- (g) AAD will use all reasonable endeavours to meet agreed delivery dates (which may be varied by mutual agreement between the parties in writing), however AAD will not be liable to the Customer for any direct, indirect or consequential loss or damage should it be delayed or prevented from delivering Goods or supplying services due to any circumstances beyond AAD's control: Time is not of the essence in relation to delivery.
- (h) Subject to clause 7(f), where the date of delivery is postponed, the Goods in respect of the Order will be stored at the Customer's risk and AAD reserves its right to impose a weekly storage charge plus a loading charge of 10% of the total Contract price.
 - (i) Where the date of delivery is postponed for more than 2 months, AAD may (i) Increase any fixed contract prices to reflect AAD's current list price; (ii) deem delivery is frustrated and sell any such Goods still in its possession; or (iii) seek damages for any loss incurred by AAD as a result of the deferment in the delivery date.

8. Title and related matters

- (a) The legal and equitable ownership and title to the Goods shall not pass to the Customer until AAD receives full payment for the Goods from the Customer. Risk in the Goods passes to the Customer upon delivery or upon title in the Goods passing to the Customer (whichever is earlier).

- (b) Until full payment has been received, the Customer acknowledges that it holds the Goods as bailee for AAD and a fiduciary relationship between the Customer and AAD exists.
- (c) Subject to clause 8(d), the Customer must:
- keep the Goods separate and in good condition as a fiduciary of AAD, clearly showing AAD's ownership of the Goods;
 - keep accurate books and record recording AAD's ownership of the goods and the Customer's sale or permitted disposal of the Goods; and
 - if required by AAD, deliver the Goods up to AAD.
- (d) The Customer may sell the Goods, install or affix the Goods to other goods or property ("Accession") or otherwise dispose of the Goods in the ordinary course of its normal business, provided that the Customer holds the proceeds of sale on trust for AAD to the extent of the Amount Payable. The Customer must hold such proceeds separate on trust for AAD and not mix those proceeds with any other monies.
- (e) The Customer grants to AAD a security interest in the Goods to secure payment of the Amount Payable, where the security interest extends to and continues in all proceeds and/or Accessions; and is a purchase money security interest to the extent that it secures payment of that part of the Amount Payable being the aggregate unpaid purchase price of the Goods supplied to the Customer.
- (f) The Customer must not do or permit anything to be done that may result in the purchase money security interest granted to AAD ranking in priority behind any other security interest.
- (g) The Customer:
- waives the right under section 157 of the PPSA to receive a copy of the verification statement verifying registration of a financing statement or a financing change statement relating to a security interest created under the Contract; and
 - contracts out of its rights to receive any other notice or statement under any other provision of the PPSA (Including for the avoidance of doubt, any of the provisions specified in paragraph (b)).
- (h) To the fullest extent permitted by the PPSA, the parties agree to contract out of sections 95, 117, 118, 120, 121(4), 125, the second sentence of section 126(2), sections 129(2), 129(3), 130, 132(3)(d), 132(4), 135, 142 and 143, which sections (or parts of sections) shall not apply.
- This clause 8 applies notwithstanding any arrangement under which AAD provides credit to the Customer.

9. Guarantee

- (a) In consideration for the supply of the Goods to the Customer and at the request of AAD, the Customer agrees to appoint:
- where a company, the Customer's duly appointed directors, whether past, present or future; or
 - where an individual sole trader, the Customer acting in his personal capacity, as Guarantors under these Terms and Conditions.
- (b) The Guarantor, and where more than one, jointly and severally, unconditionally and irrevocably guarantees:
- the punctual payment of the Amounts Payable (Including interest and damages), in connection with the supply of Goods to the Customer or any transaction contemplated by the Terms and Conditions, whether present or future, actual or contingent or Incurred alone, jointly and/or severally, and without regard to the capacity in which the Customer is liable (Guaranteed Moneys"); and
 - the due observance and performance by the Customer of all its duties and obligations contained or implied in the Terms and Conditions (Guaranteed Obligations").
- (c) In the event the Customer fails to make due and punctual payment or performance of the Guaranteed Moneys or Guaranteed Obligations (respectively), AAD demand (in writing) that the Guarantor carries out the relevant obligation in lieu of the Customer. The Guarantor must comply with such written demand immediately, failing which AAD may enforce its rights and remedies, personally against the Guarantor, regardless of whether it may have recourse against the Customer.
- (d) Without prejudice to any other rights or remedies available to AAD, the Guarantor grants security for its duties and obligations under this clause 9 by way of charge pursuant to clause 10.
- (e) In undersigning the Terms and Conditions, the Guarantor acknowledges that:
- AAD is providing supply to the Customer in reliance on this guarantee;
 - the Guarantor expects to derive a direct or indirect commercial benefit from providing this guarantee;
 - it has sought, or had the opportunity to seek, independent legal advice with respect to the nature and extent of its duties and obligations as Guarantor under these Terms and Conditions; and
 - it provides this guarantee free from any influence, duress or undue pressure from any other third parties.
- (f) The guarantee contained under this clause 9 is continuing and will survive any rightful termination of these Terms and Conditions or associated Contract.

10. Security

- (a) The Customer acknowledge that the Terms and Conditions constitute a security agreements and that AAD may register a financing statement in respect of the security interests provided herein.
- (b) Without prejudice to any other provision contained herein, the Customer and the Guarantor grants by way of charge in favour of AAD all of its interest in the Customer's and Guarantor's present and after-acquired real property to secure the performance of the Customer's obligations under the Contract, Including payment of the Amount Payable.
- (c) The Customer and/or Guarantor acknowledges that AAD have:

- a caveatable interest in any real property of the Guarantor and hereby provides its consent for AAD to lodge a caveat over that property. Upon demand by AAD, the Guarantor agrees to immediately execute a mortgage on terms satisfactory to AAD to more particularly describe the security interest conferred by this clause;
 - a registrable security interest (as defined under the Personal Property Securities Act 2009 (Cth)) in all present and after-acquired personal property of the Guarantor and hereby consents for AAD to register a security interest over that property.
- (d) Upon demand, the Customer and/or Guarantor agrees to immediately execute a mortgage on terms satisfactory to AAD to more particularly describe the security interest conferred by this clause 10. Should the Customer and/or Guarantor fail within a reasonable time of such demand to execute that mortgage, then the Customer and/or Guarantor irrevocably appoints AAD as its attorney with authority to do on its behalf any thing that it may lawfully authorise an attorney to do including, without limitation, to make, sign, execute, seal and deliver any document and to take possession of, use, sell or otherwise dispose of any real property of the Customer, to the extent of the Amount Payable.

11. Installation

AAD's Sale Invoice is made on a supply only basis. Installation and commissioning (if any) is at the expense of the Customer unless otherwise specified in writing by AAD.

12. Dimensions, Performance Data and Product Descriptions

- (a) Any and all photographs, drawings, illustrations, specifications and any other particulars accompanying associated or given with a Quotation or Order ("Product Specifications"), is for illustrative purposes only and may be subject to alteration without notice.
- (b) If the Customer receives any confidential information from AAD, Including but not limited to the Quotations or the Product Specification, the Customer may not use or disclose such information unless it receives the prior written consent of AAD, such information enters the public domain (other than as a result of a breach of this clause) or the use or disclosure is required by law. Upon termination of the AAD's relationship with the Customer, all confidential information must be returned to AAD (or erased where applicable) on demand.

13. Claims and Returns

- (a) All complaints, requests for return of goods, claims, or notification of lost, Incomplete, damaged, defective or non-compliant goods must be submitted by the Customer to AAD in writing within 5 days of the date of delivery of the Goods. Otherwise, the Customer shall be deemed to have accepted the Goods and shall not refuse to pay for the Goods on the basis that they were lost, incomplete, damaged, defective or do not comply with the Customer's Order.
- (b) While AAD will use all reasonable endeavors to deliver goods as specified in the Order, Customer acknowledges and agrees that it is the Customer's sole responsibility to ensure that goods delivered align with the Order. AAD is not liable to Customer or any end user for any goods purchased and or subsequently installed that are different to that specified in original Order.
- (c) AAD will not accept the return of goods unless the following conditions are satisfied:
- AAD's written approval has first been obtained;
 - the goods are returned within 7 days of the issue of AAD's approval;
 - a copy of the relevant invoice is enclosed with the returned goods;
 - the goods are returned in merchantable quality (as determined solely by AAD) with the original packaging and without damage or marks to the original packaging;
 - the Customer pays shipping costs for the return of goods to a warehouse or other premises nominated by AAD; and
 - the Customer pays to AAD a handling charge equal to 15% of the Purchase Price paid for the Goods.
- (d) Unauthorised returns will not be accepted. The Customer will be responsible for all damage Incurred during return shipment.
- (e) The Customer shall not deduct the amount or any anticipated credit from any payment due to AAD.

14. Default

- (a) A party will be in Default if:
- it breaches a term of the Contract and such breach is not remedied within 14 days of receiving notice from the other party requiring it to do so, unless such breach arises out of the supply of defective Goods, in which case AAD shall remedy the breach within such time as is reasonable in the circumstances;
 - it becomes an externally-administered body corporate or has an application for winding up filed against it, or alternatively, it commits an act of bankruptcy or becomes an insolvent under administration;
 - in the case of the Customer, payment for the Goods has not been received by the due date of payment;
 - in the case of the Customer, any representation or warranty made by it in or in connection with the Contract, or any information provided by it to AAD in or in connection with the Quotation, Order or Contract, is incorrect, misleading or deceptive (whether by omission or otherwise) in any material respect; or
 - in the case of the Customer, AAD forms the opinion in its absolute discretion that the Customer's creditworthiness or credit standing alters from that indicated at the time of making the Order.

- (b) If a party Defaults, the other party may:
- (i) treat an Order Acknowledgement or the whole of the Contract as repudiated and sue for breach of contract; and/or
 - (ii) being AAD, charge Interest pursuant to clause 5 on any unpaid and outstanding Amounts Payable;
 - (iii) being AAD, refuse to supply any Goods to the Customer on credit or at all;
 - (iv) being AAD, claim the return of any Goods in the Customer's possession where title has not passed to the Customer or exercise any other right or remedy available to it under the Contract, the PPSA or any other applicable law, Including to enforce the security interests created by the Contract;
 - (v) being AAD, by notice to the Customer declare all monies owing by the Customer to AAD on any account immediately due and payable (Including the Amount Payable);
 - (vi) enter (at any time) any premises in which AAD's goods are stored, to enable AAD to reclaim possession of the goods without liability for the tort of trespass, negligence or payment of any compensation to the Customer or any Receiver Manager or Administrator appointed over all or any part of its assets. For the avoidance of doubt, title in the goods immediately re-vest in AAD upon AAD asserting its right of entry under this clause 14(b)(vi);
 - (vii) institute any recovery process as AAD in its discretion decides, at the Customer's cost and expense (full indemnity basis).
- (c) The rights, powers and remedies available to AAD under these Terms and Conditions are in addition to and are not in derogation to AAD's powers, rights and remedies existing at common law, or given by any law at any time in force (Including but not limited to the Building and Construction Industry Security of Payment Act 2002 (Vic)).
- (d) The Customer hereby irrevocably appoints all and any of AAD's officers, company secretary, accounts manager or legal personal representative engaged by AAD as AAD's lawful attorney for the purposes of doing all such acts and things and executing all such documents necessary to enable AAD to do any or all of the above things contained in this clause.

15. Alteration to Terms and Conditions

AAD may amend or vary these terms and conditions at any time by written notice to the Customer's place of business or by posting an amended copy on AAD's website www.AAD.net.au and that the Customer will be bound by any such amendments.

16. Warranties as to Supply

- (a) AAD reserves the right to suspend or discontinue supply of Goods to the Customer at any time for any reason without liability or penalty.
- (b) AAD has continuing discretion to allocate available stock and gives no warranty as to certainty of supply.
- (c) In the event of a product Recall ("Recall"), the Customer must give AAD such assistance as AAD reasonably requires in relation to that Recall:

17. Representations and Fitness for Purpose

- (a) Except as expressly provided to the contrary in the Contract, all representations, warranties, guarantees and implied terms or conditions in relation to the Goods (whether implied or otherwise) are hereby excluded to the maximum extent permitted by law.
- (b) The Customer agrees that if it is aware (or should be aware) that the Goods, the subject of an Order, are for a particular purpose (Including, but not limited to, use as a component part of another product) or are required to possess special or uniform characteristics, the Customer will clearly specify that purpose or those characteristics in any such Order.
- (c) The Customer agrees that, unless expressly agreed by AAD in writing, it has made its own enquiries in relation to the suitability of the Goods and does not rely on representations by AAD in relation to their suitability for a particular purpose or any steps which may need to be taken in relation to their use.

18. Limitation of Liability

- (a) AAD's liability to the Customer (and any party claiming through the Customer against AAD) for any claim for loss or damages (Including legal expenses) made in connection with the Contract (Including the supply of Goods described in the Contract) whether in contract, tort (Including negligence), under statute, in equity or otherwise shall be strictly limited as follows (except to the extent that the law prohibits such a limitation):
 - (i) for any liability arising from Goods not meeting the specification or which are said to be otherwise defective or deficient, AAD's liability is limited to the cost of replacement of those Goods as soon as reasonably practicable, or the repair of those Goods or the repayment (or allowance) of the invoice price of those Goods (at the option of AAD);
 - (ii) for any liability arising from the services forming part of the Goods not meeting the scope or which are said to be otherwise defective or deficient, AAD's liability is limited to the provision of the services again or payment of the cost of having the relevant services provided (at the option of AAD);
 - (iii) for any other liability, AAD's liability for any loss or damage arising from or caused in any way by AAD, the Goods it supplies or the Contract is excluded (to the maximum extent permitted by law).
- (b) AAD shall not be liable, to the maximum extent permitted by law, for any indirect, special or consequential loss or damage or injury of any nature whether in contract, tort or otherwise whatsoever resulting from or caused in any way by the Goods it supplies, even if due to the negligence of AAD or any of its employees or agents. Here, "indirect, special or consequential loss or damage" INCLUDES: (A) any loss of income, profit, production, contract, customers, business opportunity or business; (B) any loss of goodwill or reputation; (C) any loss of value of intellectual property; (D) any loss or damage resulting from the loss or damage to goods other than the Goods.

(c) Despite any other provision of the Contract, AAD is not liable, to the maximum extent permitted by law, for:

- (i) the cost of removal of Goods not meeting the specification or which are said to be otherwise defective or deficient, whether installed or otherwise;
- (ii) the cost of installation of replacements for Goods not meeting the specification or which are said to be otherwise defective or deficient; and
- (iii) defects or deficiencies in Goods caused by improper storage, installation or maintenance of Goods or normal wear and tear damage.

19. Manufacturer's Warranty

- (a) The Customer agrees that AAD is not the manufacturer of any Goods and AAD shall not be liable to any party as a manufacturer.
- (b) Goods are sold subject to any manufacturer's trading terms and conditions and are covered (if at all) by any manufacturer's warranty applicable thereto. All warranty claims are to be made by the Customer directly to the manufacturer.
- (c) If AAD is deemed to be a manufacturer of any Goods in any circumstances, the Customer will fully indemnify AAD against any liability loss or cost associated with or arising as a result of such deeming:

20. Force Majeure

AAD is not liable for failure to perform its obligations under the Contract to the extent and for so long as its performance is prevented or delayed without substantial fault or negligence by AAD because of circumstances outside AAD's control or failure of a supplier to AAD, provided that AAD gives notice to the Customer of the delay and uses reasonable efforts to remedy the cause of the delay quickly.

21. Entire Agreement

- (a) The Contract constitutes the entire agreement between AAD and the Customer with respect to any Order. All prior negotiations, proposals, previous dealings, correspondence, trade customs and/or trade usage are superseded by and will not affect the interpretation of the Contract.
- (b) In the event of supply, the Customer refers to or submit or otherwise uses terms and conditions other than the Terms and Conditions, these terms and conditions will not form part of or be incorporated into the Order or Contract, unless otherwise expressly accepted.

22. Costs and Expenses

The Customer must pay AAD all costs and expenses incurred by AAD in connection with the Contract including legal expenses (on a full indemnity basis), stamp duty (including fines and penalties) and costs incurred or payable by AAD in connection with registering, maintaining or releasing any security interest, charge, mortgage or caveat in connection with the Contract, or the recovery of the Amount Payable or in otherwise enforcing AAD's rights against the Customer under the Contract. The costs of registering any PPSA financing statement will be paid by the Customer and may be invoiced or debited against the Customer's credit account.

23. Assignment or Sub-Contracting

- (a) AAD may assign or sub-contract its rights or novate its rights and obligations under the Contract (in whole or in part) to any person without the consent of the Customer.
- (b) The Customer must not assign or otherwise transfer its rights under the Contract without prior notice to and consent from AAD.

24. Governing Law

- (a) The Contract is governed by, and the Customer submits to the law of the State of Victoria, Australia. The courts of that State have non-exclusive jurisdiction in connection with the Contract.
- (b) The Sale of Goods (Vienna Convention) Act 1987 (Vic) (and any similar legislation relating to the Vienna Convention in other States or Territories) does not apply to the Contract.

25. Waiver

Except as expressly set out in the Terms and Conditions, a party waives a right under the Contract only by written notice that it waives that right. A waiver is limited to the specific instance to which it relates and to the specific purpose for which it is given.

26. Notices

Notices must be in writing and by mail, email or facsimile transmission. The Customer must promptly notify AAD in writing of any change to its registered address or other contact details provided to AAD.

27. Discretion

Any and all discretions to be made in respect of these Terms and Condition must be made by such parties acting reasonably in view of the prevailing circumstances at the time.

28. Time

Unless otherwise expressed, time is of the essence in relation to the performance of the duties and obligations contained in the Terms and Conditions.

29. Severance

The invalidity or unenforceability of any provision of these Terms and Conditions shall not affect the validity or enforceability of the remaining provisions.

30. Assurances

These Terms and Conditions bind the Customer, the Guarantors and their respective successors and assigns.



Note: The Components Catalogue V2 contains information on the whole range of components that AAD sell.

Copyright: These materials are copyright. No part of them may be reproduced, adapted, translated, or transmitted without the prior written permission of the copywrite owner, Australian Airconditioning Distributor. Except under any permitted circumstances set out in the Copyright Act 1968.

AAD - Australian Airconditioning Distributors
ABN - 43 139 947 363



COMPONENTS CATALOGUE

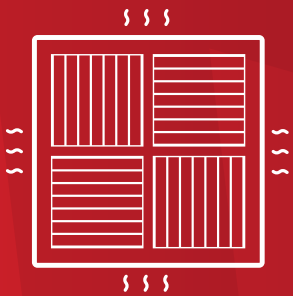

aad.net.au

V2

DIRECT TO TRADE